



Rear Differential Slider Skid Plate

FOR Chevy Colorado/GMC Canyon

2023 - Current

INSTALLATIONGUIDE



INCLUDED PARTS	QTY	REQUIRED TOOLS
Fuel Tank Skid Plate	1	Ratchet (3/8")
Hardware Pack	1	Torque Wrench
U Bolts	2	15MM Socket
Clamp	1	Jack stand

PLEASE READ BEFORE YOU START

To guarantee a quality installation, we recommend reading these instructions thoroughly before beginning any work. These instructions assume a certain amount of mechanical ability and are not written nor intended for someone not familiar with auto repair.

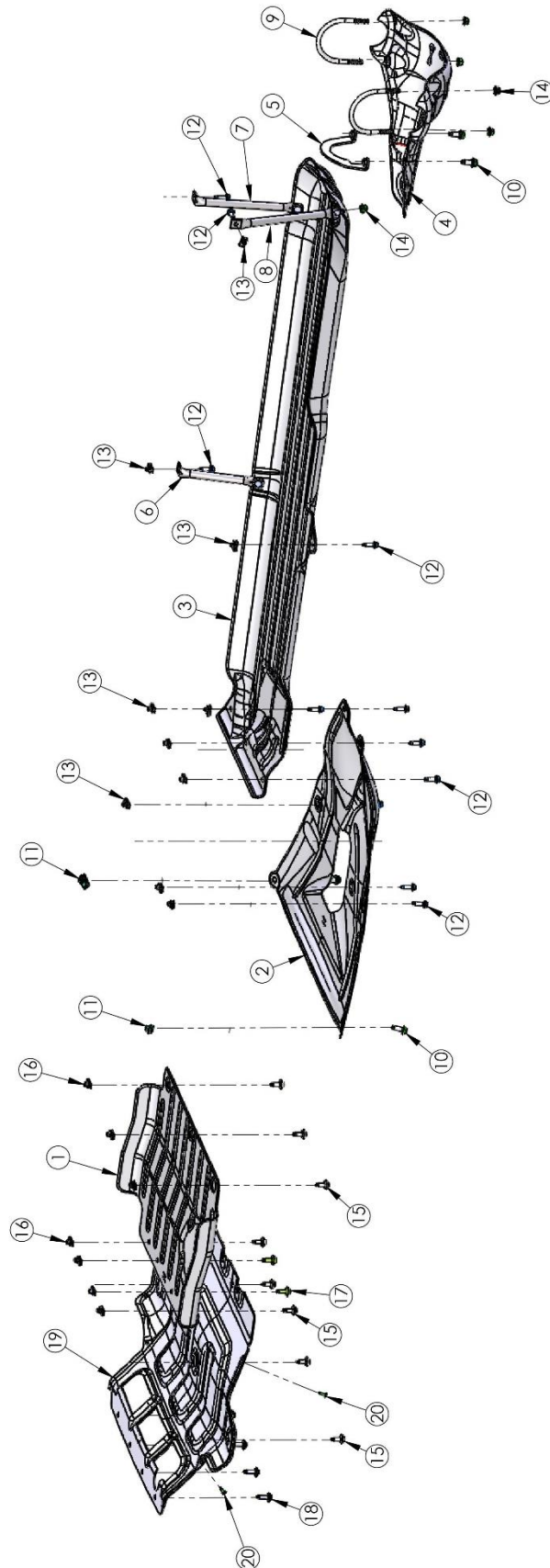



ITEM NO.	PartNo	DESCRIPTION	QTY.
1	A32P1200AA	FRONT IFS SKID, STAMPING, 31XX-2 SKID PLATES	1
2	A32P1300AA	TRANSMISSION SKID, STAMPING, 31XX-2 SKID PLATES	1
3	A32P1400AA	FUEL TANK SKID, STAMPING, 31XX-2 SKID PLATES	1
4	A32P0195AB	REAR DIFF SLIDER, WELDMENT, 31XX-2 SKID PLATES	1
5	A32P0192AA	CLAMP, REAR DIFF, WELDMENT 31XX-2 SKID PLATES	1
6	A32P0142AB	PENCIL BRACE, FRT INBOARD FUEL TANK, 31XX-2 SKID PLATES	1
7	A32P0143AB	PENCIL BRACE, RR INR FUEL TANK, 31XX-2 SKID PLATES	1
8	A32P0144AB	PENCIL BRACE, RR OTR FUEL TANK, 31XX-2 SKID PLATES	1
9	A32P1953AA	U-BOLT, 31XX-2 SKID PLATES, REAR DIFF SLIDER	2
10	11588738	M10 X 1.5 X 25 HEX FLANGE BOLT	4
11	11548589	M10 X 1.5 U-NUT (PANEL THICKNESS RANGE 1.5-5.5)	2
12	11588724	M8 X 1.25 X 30 HEX FLANGE BOLT	11
13	11548587	M8 X 1.25 U-NUT	10
14	11546366	M10 X 1.5 HEX FLANGE LOCK NUT	7
15	11519388	M8 X 1.25 X 25 HEX SCREW AND WASHER	8
16	11602085	M8 X 1.25 U-NUT (PANEL THICKNESS 0.8-4.0)	7
17	11611334	M8 X 1.25 X 30 HEX SCREW AND WASHER ASM	2
18	11603624	M8 X 1.25 X 34.05 13mm HEX SOC, M-PT	4
19	A32P1100AB	RADIATOR SKID, 31XX-2 SKID PLATES	1
20	11611883	M4.2 X 1.41 X 20 TORX PAN HEAD SCREW (BR POINT, T15)	4

I. VEHICLE PREPARATION

1. Remove factory Rear Differential Slider Skid Plate (If applicable).
2. AEV Skid Plate Installation order if installing multiple skid plates:
 - A. AEV Front IFS Skid Plate, then AEV Radiator Skid Plate (Radiator Skid requires AEV front bumper).
 - B. AEV Fuel Tank Skid Plate, then AEV Transmission Skid Plate
 - C. Rear Differential Slider Skid plate (Independent)
3. Place U bolts over differential as shown.



Figure 1

4. Align AEV Rear Differential Skid Plate to U Bolts and loosely tighten 4 M10 Nuts.
 - A. Make sure to evenly tighten U-Bolts, allowing three rotations of thread on either side protruding from nut.
5. Align Clamp A32P0192 with bolts facing the rear of the vehicle with contact to metal, not to the gasket. loosely tighten M10 Bolts



Figure 2

6. Align Tighten bolts to designated FT/LBS
 - A. M10 42 FT/LBS