

Installation Guide for the 2023+ Chevy Colorado/GMC Canyon off-road bumper winch (PN 19433054)

Installation Summary

- A. Determine if Center Console Auxiliary Switch is Unused
- B. Prepare Off-Road Bumper for winch Installation
- C. Winch Controller and Mount Bracket Installation
- D. IRAP (Ignition Retained Accessory Power) Wire Installation and ON/OFF Switch Wire Installation (as appropriate) in Passenger Foot Compartment Area
- E. Winch Controller Power Cable and Mega fuse holder bracket Installation
- F. Winch controller harness to winch routing & Wired Remote Plug Installation
- G. Chassis ground cable attachment(s) to battery ground
- H. Install winch into Off-road Bumper Assembly
- I. 3-gang switch installation – GM PN 84938259 **(ONLY IF REQUIRED IN STEP A – CENTER CONSOLE AUXILIARY SWITCH IS NOT AVAILABLE FOR WINCH USE)**
- J. Final harness to battery connections & winch operation check

A. Determine if Center Console Auxiliary Switch is Unused

1. Determine if the Center Console Auxiliary Switch (first two pictures below) has been wired for use with any other accessory such as lights, etc.
 - a. If no, then the Center Console Auxiliary Switch will be used to turn on/off the winch system.
 - b. If yes, then the 3-gang accessory switch (GM PN 84938259 - Auxiliary Multifunction Switch Package) must be installed to turn on/off the winch system (See step I – Winch On/Off switch installation). If the 3-gang switch is not already installed at the driver left knee bolster, then the part must be ordered for installation.



3-gang switch bank

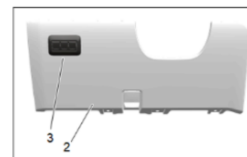
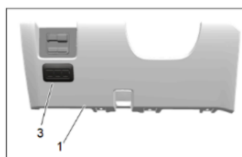

B. Prepare Off-Road Bumper

1. Raise and suitably support the vehicle. Refer to Vehicle Service Manual.

2. Remove the front wheel and tire assemblies (off-road bumper not shown)

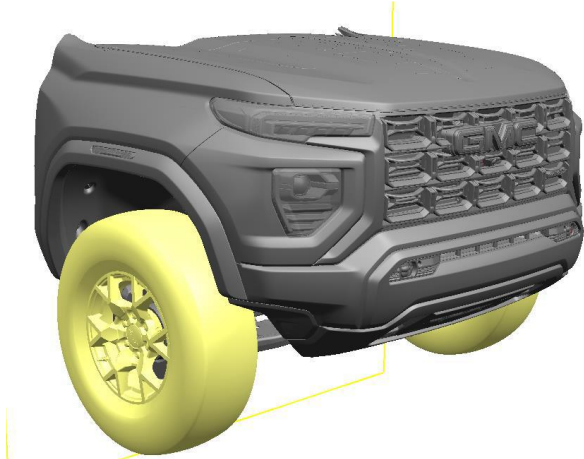

3. Partially remove the passenger side front wheel liner (See Service Information - Document ID: 6276716 [Document ID: 6276716 \(gm.com\)](https://gm.com)).
 - a. Remove the front half of the wheelhouse liner. Front Wheelhouse Liner Bolt (1) » Remove [9x].

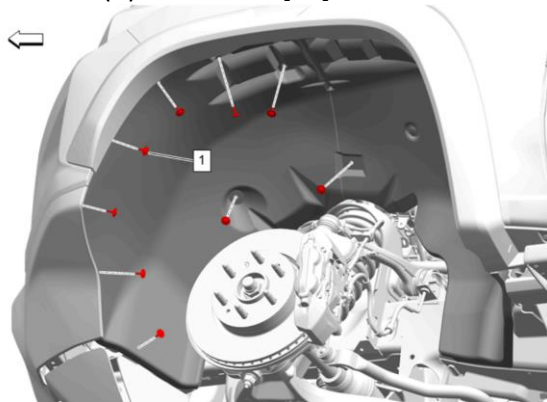

- b. Do not remove the rear half of the wheel house liner, but remove the Front Wheelhouse Liner Retainer (1) and the single forward most Front Wheelhouse Liner Bolt (2).

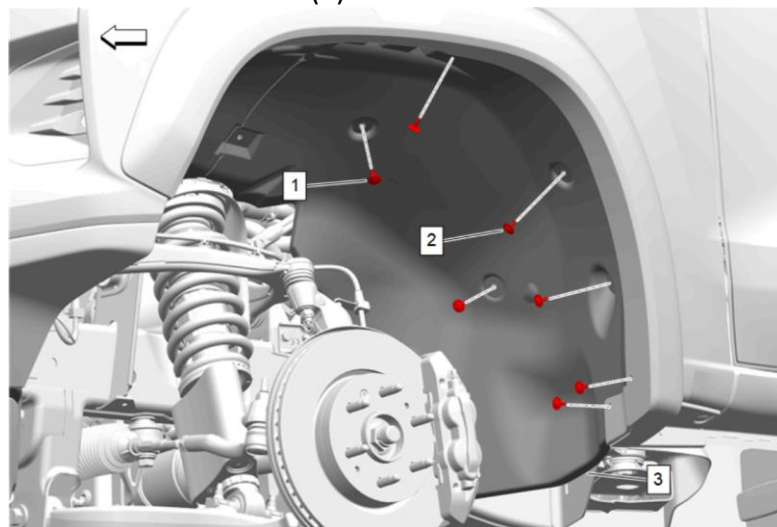

- c. Peel back the rear half of the wheel house liner to reveal the hole shown below. This will be used as a winch controller mount bracket attachment point in later steps.

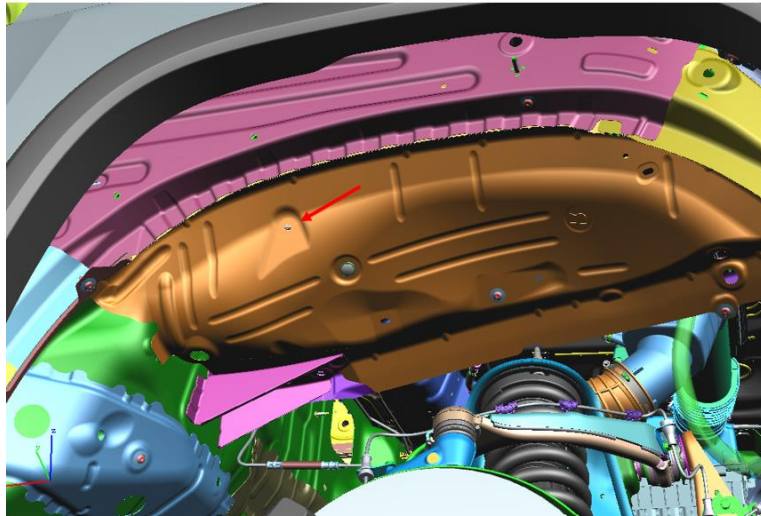

4. Remove the driver and passenger side front bumper fascia molding

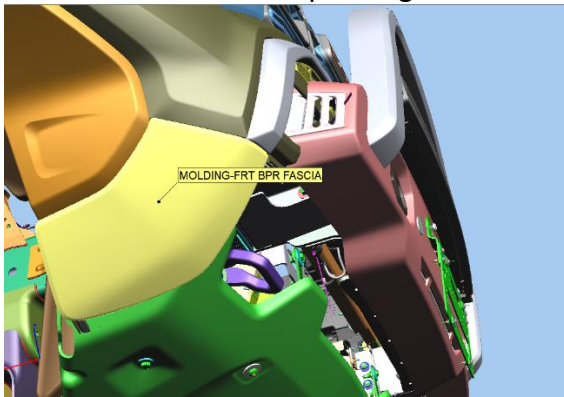

5. Remove the plastic fog lamp bezel 4/side screws. Retain screws and parts for re-installation later. Reference Service Information - Document ID: 6374430 "Pull Winch Replacement ([Document ID: 6374430 \(gm.com\)](https://gm.com)) for this and all following steps to prepare the Off-Road Bumper for winch installation.
 - a. Front Bumper Fascia Bolt - Left Side and Right Side (1) » Remove [8x]
 - b. Front Fog Lamp Opening Cover - Left Side and Right Side (2) » Remove [2x]

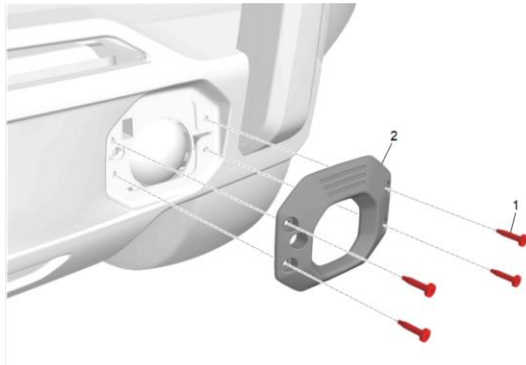

6. Disconnect the light bar harness (if present) to aid removal of fog lamps.

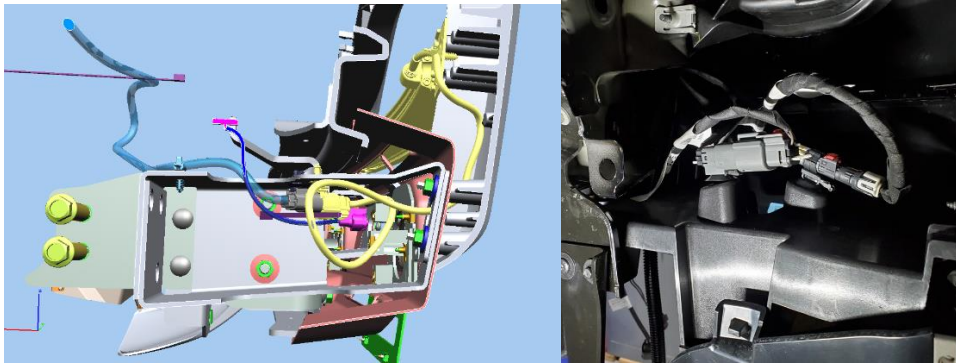

7. Carefully reach up through the opening of the front bumper impact bar and remove the driver and passenger side front fog lamps (1). Slide the fog lamps sideways out through the off-road bumper. Use caution to not scratch the lens.

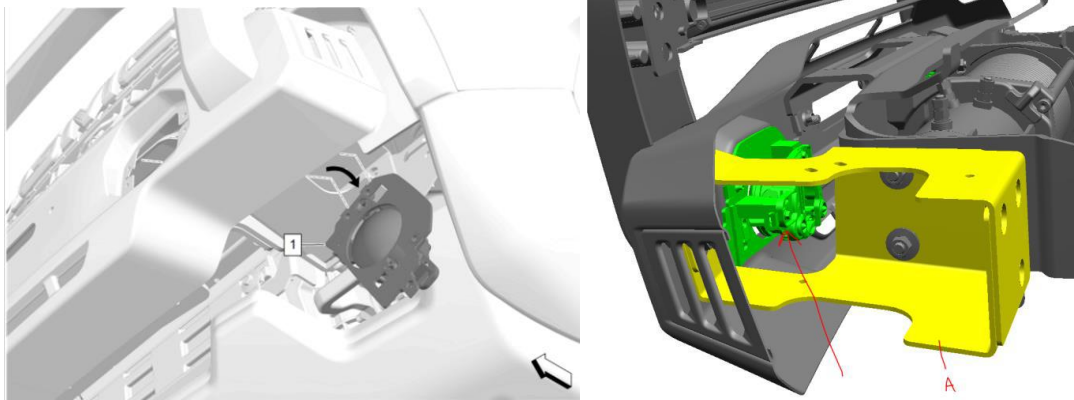

8. Disconnect all electrical connectors. Disconnect the fog lamps to the hanging wire harness.



9. {If equipped } On the right side disconnect the off-road lamp connector and retainers. It may be necessary to de-pin the off-road lamp connector. — [Terminal Removal](#)
10. Remove the front bumper impact bar.
 - a. Front Bumper Impact Bar Nut - Left Side and Right Side (1) » Remove [4x]

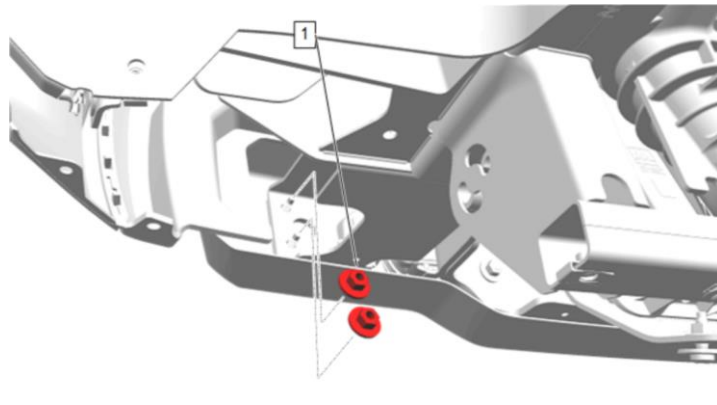

b. Front Bumper Impact Bar (1) » Remove

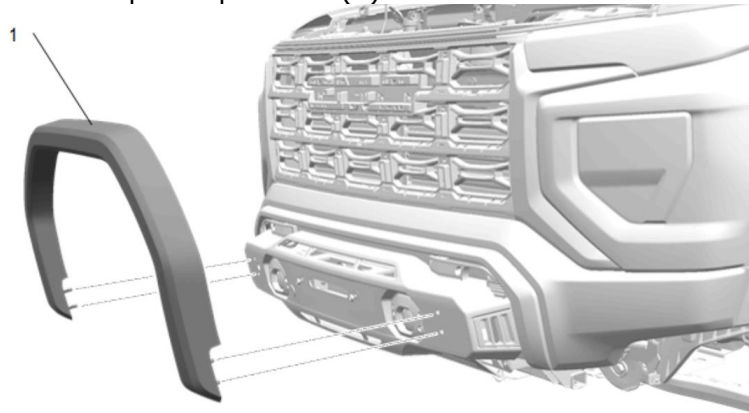

11. Remove the front license plate bracket (if installed). Retain bolts for winch fairlead and front license plate bracket (as needed) for re-installation later.

a. Front License Plate Bracket Bolt (1) » Remove [2x]

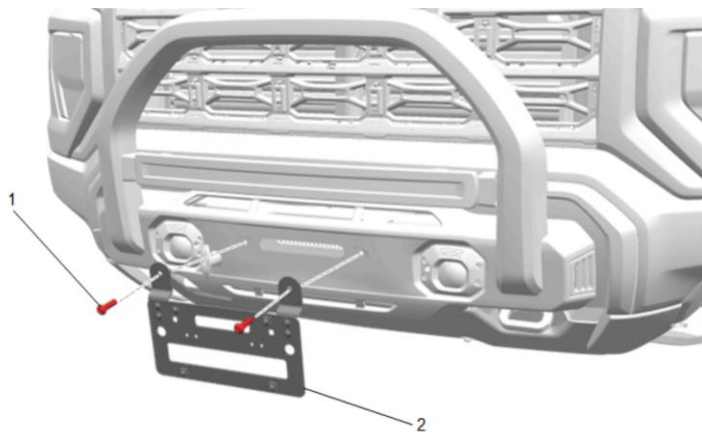

12. Remove the front bumper fascia skid plate. Front Bumper Fascia Skid Plate (1) » Remove.

13. Release the wire retainers.

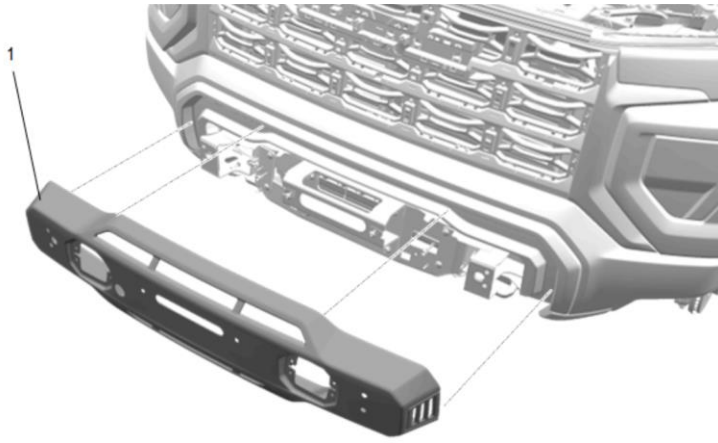

14. Remove the skid plate retention bolts. Retain bolts for re-installation later.
- a. Underbody Skid Shield Bolt (1) » Remove [5x]
 - b. Underbody Skid Shield Bolt (2) » Loosen [2x]

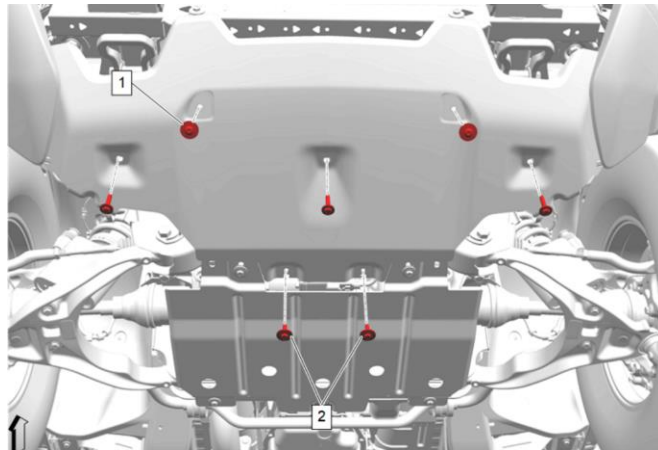

15. Remove skid plate retention screws. and skid plate
- a. Underbody Skid Shield (1) » Remove

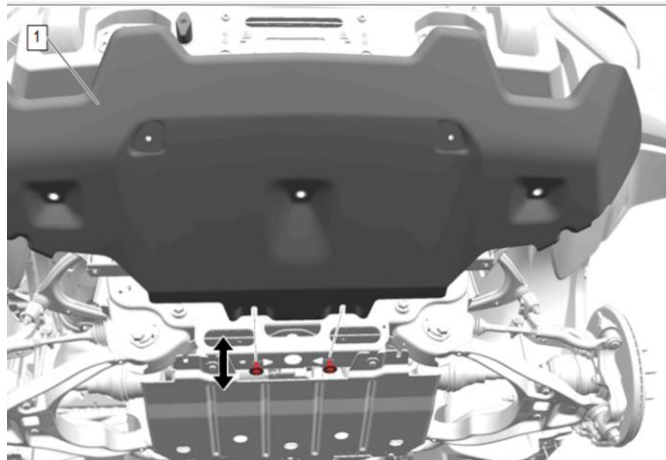

16. Remove the Underbody Splash Shield. Retain bolts and shield for re-installation later.
- a. Underbody Splash Shield Bolt (1) » Remove [2x]
 - b. Underbody Splash Shield Bolt (2) » Loosen [2x]
 - c. Underbody Splash Shield (3) » Remove

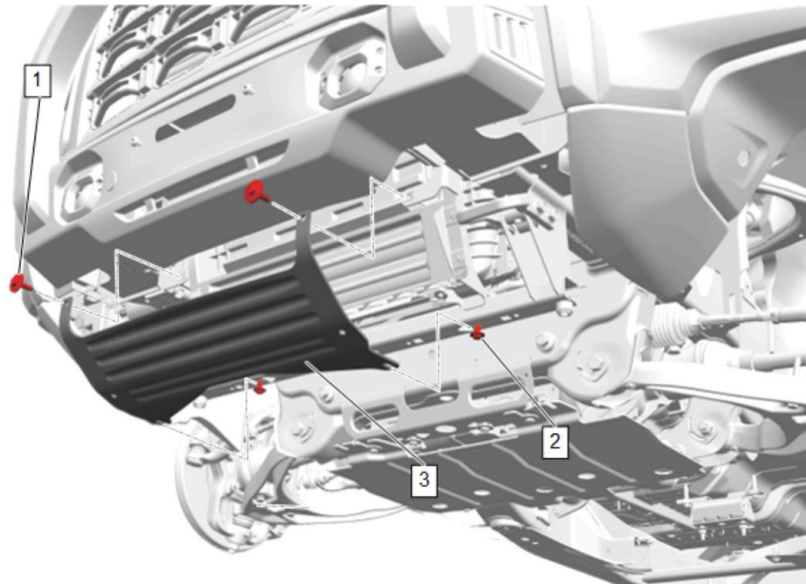

17. Remove tow hooks. Retain screws and parts for re-installation later.

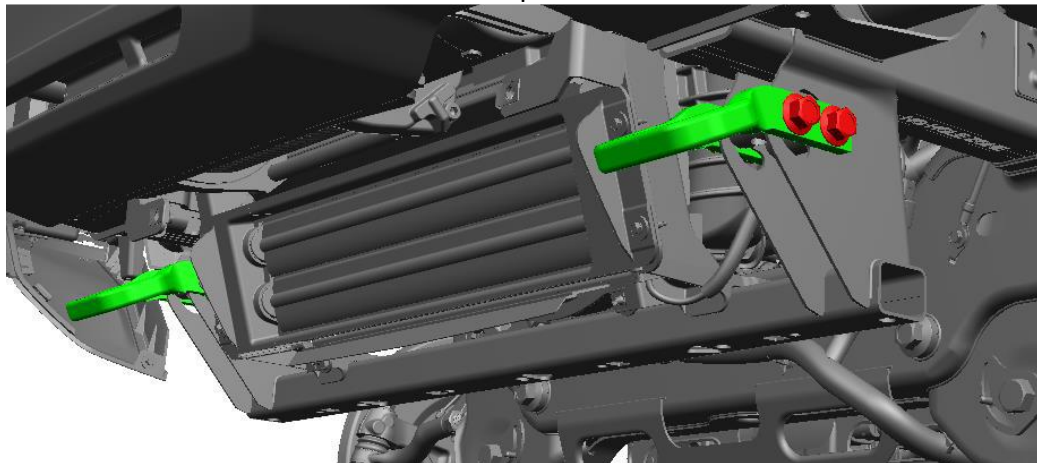

18. Disconnect the electrical connector to the shutter assembly.

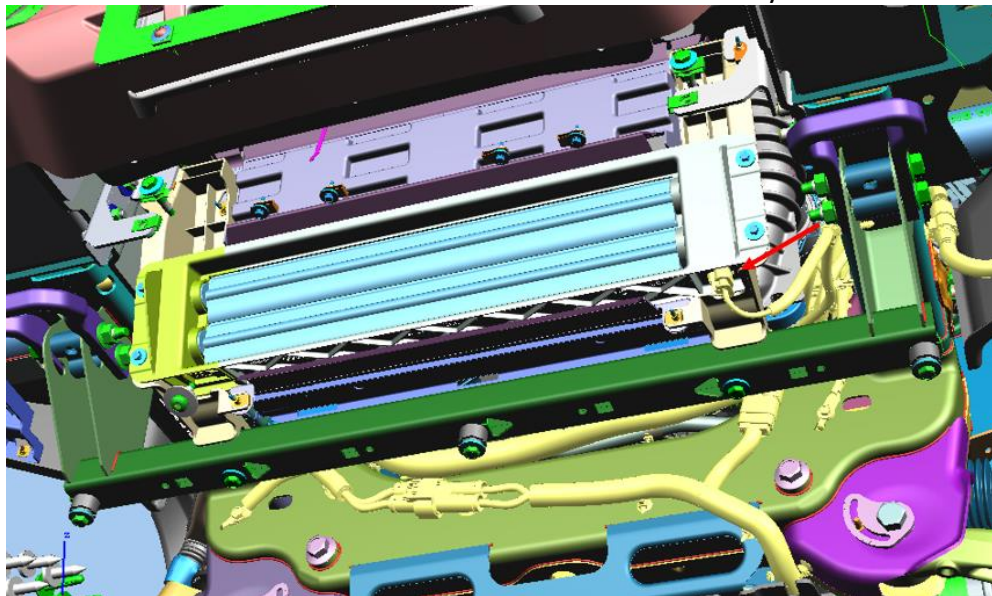

19. Remove the top and bottom active shutter assembly mounting bolts. Recommended to use electric ratchet for the top bolts. Retain for re-installation later.

- a. Front Bumper Lower Shutter Bolt - Left Side and Right Side (1) » Remove [4x]

20. Pull the bottom of the front bumper lower shutter off the cross bar and then down.

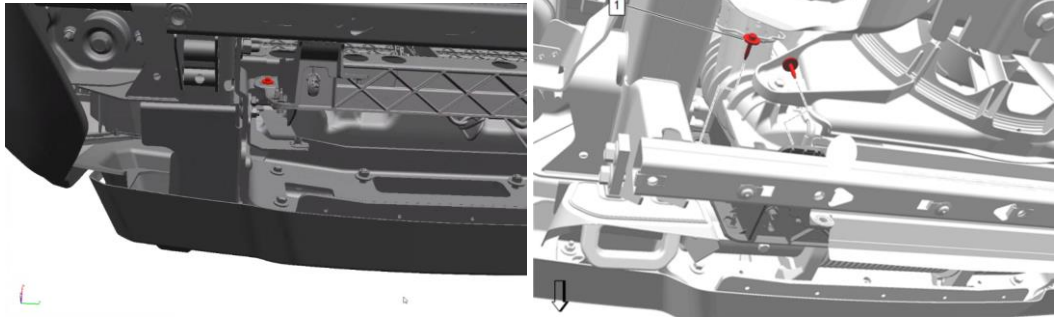

21. Remove Front Bumper Lower Shutter (1)

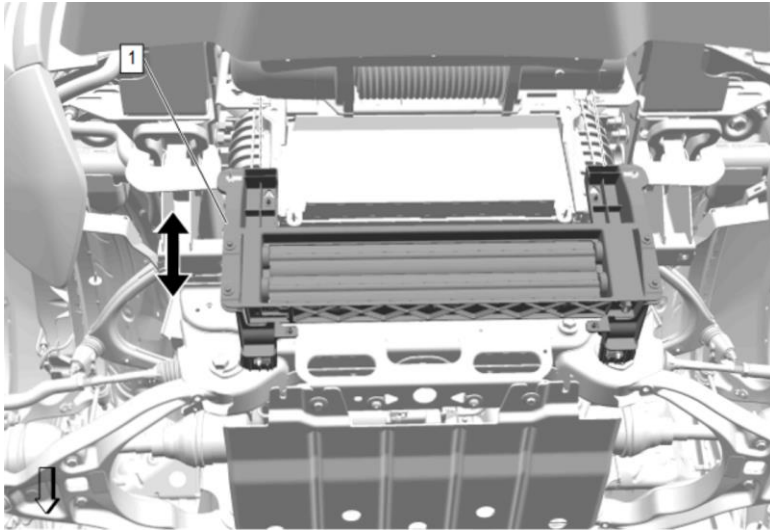

22. BEFORE removal mark both the driver and passenger side L brackets and the structure they mount on with a grease / paint pencil, so they can be re-installed in the correct fore/aft positions.

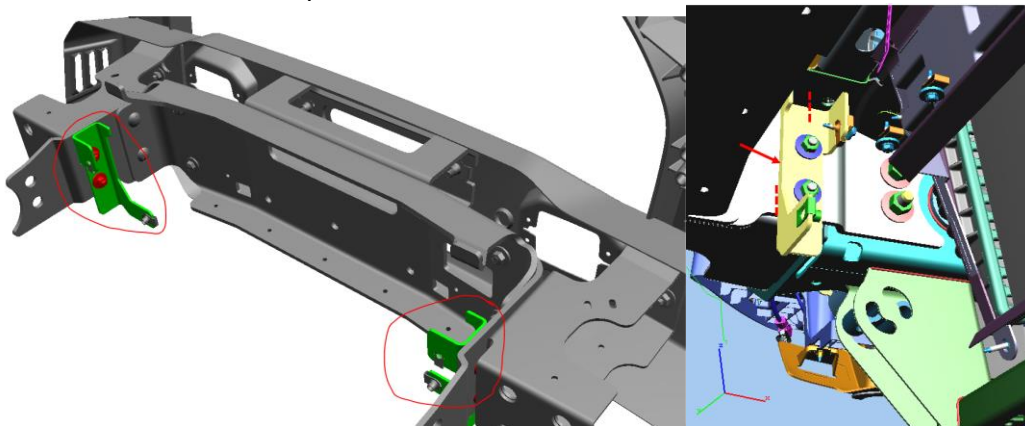

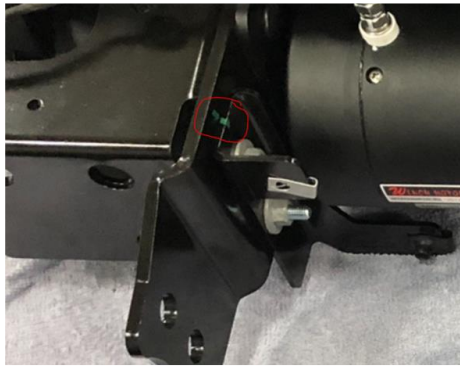
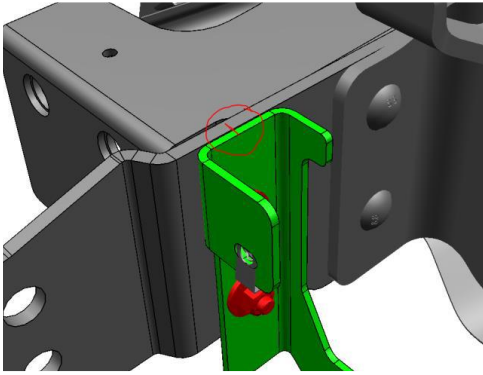

23. Remove the Winch Bracket Nuts - Left Side and Right Side (1) » Remove [4x]

24. Remove the Winch Bracket - Left Side and Right Side (2) » Remove [2x]

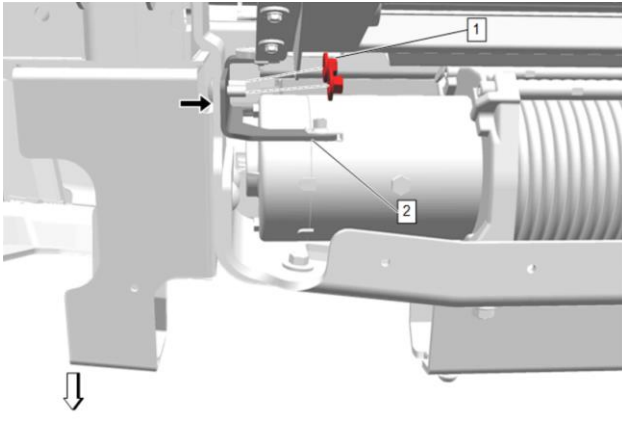

25. Remove the front bumper fascia mount bracket. Take out 4 bolts and nuts from the off-road bumper assembly. Keep bolts, and mount bracket and discard nuts.

a. Winch Bracket Bolt (1) » Remove [2x]

b. Winch Bracket Bolt (2) » Remove [2x]

c. Winch Bracket (3) » Remove

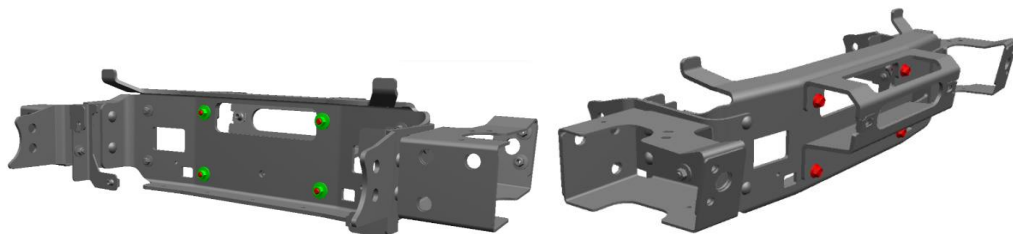
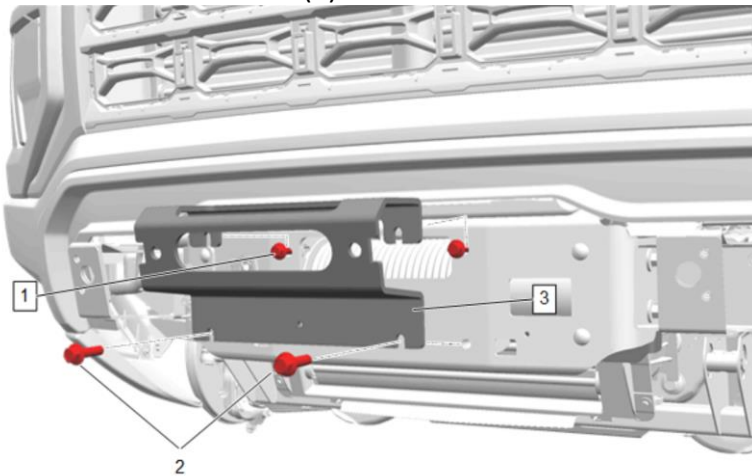

C. Winch Controller and Mount Bracket Installation

1. If present disengage the Accessory Wiring Junction Box from its mounting bracket to provide additional space to remove the battery (See Service Information - Document ID: 6058122 [Document ID: 6058122 \(gm.com\)](#)).
 - a. Disengage the retaining tab (1) from bracket (3) and remove 8-way connector (2).

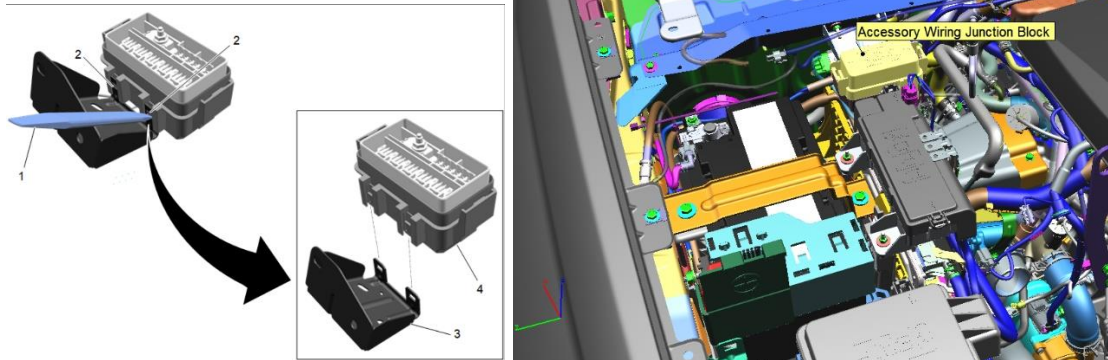

2. Remove battery assembly and the battery tray (See Service Information - Document ID: 6142605 [Document ID: 6142605 \(gm.com\)](#))
 - a. Remove the battery cross brace with two bolts
 - b. Remove the positive and negative battery terminal electrical connections
 - c. Remove the battery tray

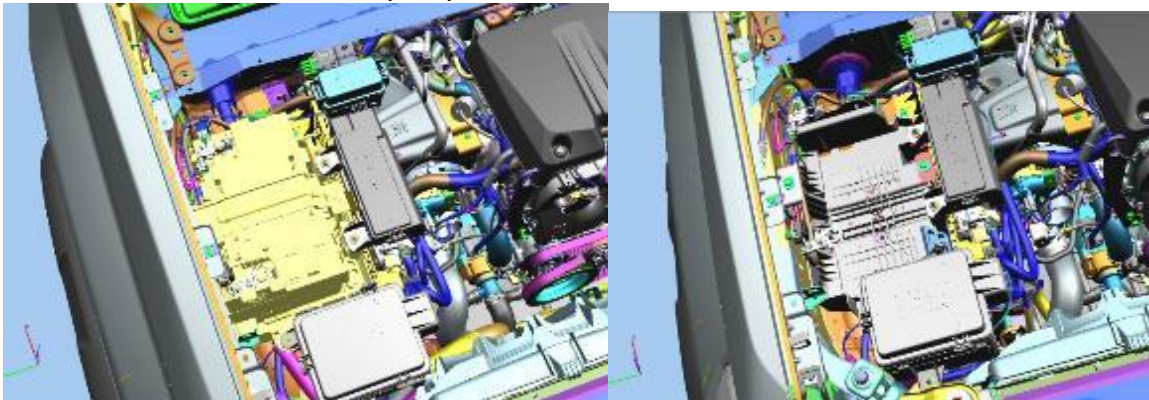

3. Install winch controller 3-legged mount bracket to the outboard engine compartment wall. There are 3 mounting holes in the bracket (see diagrams that follow).
 - a. On the wall attaching bracket's flat plane surface in the upper hole install M4 x 0.7P UNut (item 4 in controller fastener list below) and M4 x 0.7P x 20L flanged button head bolt (item 13) using a M2.5 Allen wrench.
 - b. Rearmost leg - 13 mm existing hole in wall (hole #1): Install M4x0.7Px12.6L self-aligning rivnut (item 6) using a rivnut installation tool (see picture of rivnut install tool option below).
 - c. Lowest forward leg - existing hole in wall (hole #2): Install M6 x 1.0P x 16L bolt (item 1). Secure the bolt by installing M6 x 1.0P flange nut (item 2) on the outer side of the wheel well.
 - d. Secure bracket at rearmost hole #1 (rivnut in 13 mm existing wall hole) with M4 washer (item 5) and M4x0.7 x 20 bolt (item 3).

- e. Top forward leg (hole #3) - At top forward leg mark the bracket hole (using a paint pen) and center punch the mark to drill 11 mm hole for M4x0.7Px12.6L self-aligning rivnut (item 6).
- f. Remove the bracket by removing bolts at hole #1 and #2
- g. Drill 11 mm hole at center punch mark for hole #3. Add rust preventative to the drilled hole.
- h. Install stand off tie strap (item 7) on top wall mount bracket hole. Fir tree threads are to point up toward the hood. Rotate tie strap so end of zip tie will point inward when fully closed around the ground wire (see last 2 pictures below).
- i. Position bracket over the 3 holes. Secure hole #1 and #3 with M4 washers (item 5) and M4x0.7 x 20 bolts (item 3). Secure hole #2 with M6 x 1.0P x 16L bolt (item 1) and by installing M6 x 1.0P flange nut (item 2) on the outer side of the wheel well.
- j. Loop zip tie around ground wire (see arrow in picture below) to maintain wire clearance to the wall mount bracket.

COMEUP WINCH **Controller Fastener Kit**

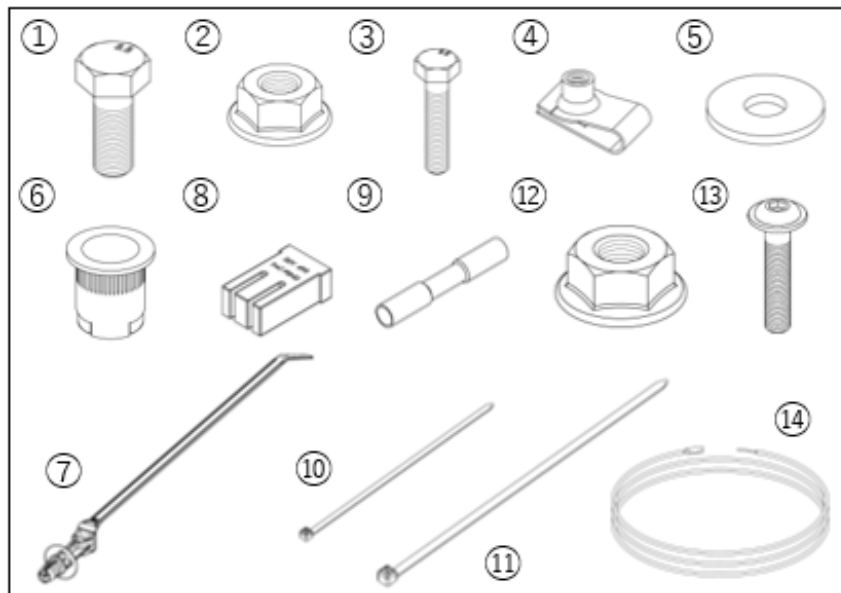

Item#	Parts Description	Qty
1	M6x1.0Px16L Bolt	3
2	M6 x1.0P Flange Nut	3
3	M4x0.7Px20L Bolt	2
4	M4x0.7P Unut	5
5	M4 Washer (OD: 12mm, thickness: 2mm)	2
6	M4x0.7Px12.6L Self-aligning Rivnut	2
7	Standoff Tie Strap	1
8	Littelfuse M-case 20A fuse	1
9	Butt Splices	2
10	Zip Ties 4.8x190mm	8
11	Zip Ties 4.8x280mm	8
12	M8 x1.25P Flange Nut	1
13	M4x0.7Px20L Flanged Button Head Bolt	5
14	IRAP Wire (Red-18AWG/600mm)	1

Standoff Tie Strap (item 7)
 GM 84199186
 Helleman Tyton 157-00199

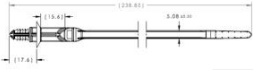

Hole #3: Drill 11mm recommended hole for M4x0.7Px12.6L self-aligning rivnut (item 6)

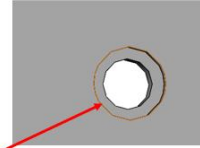
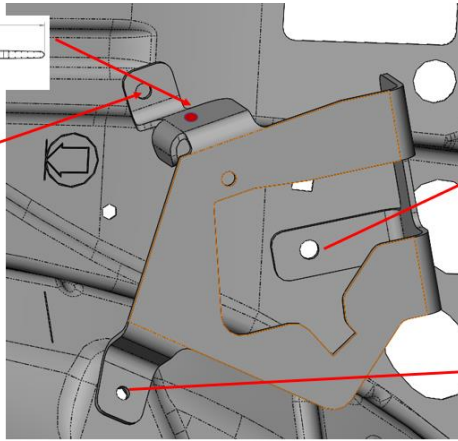

Hole #1: 13mm Existing Hole (outside view) for M4x0.7Px12.6L self-aligning rivnut (item 6)

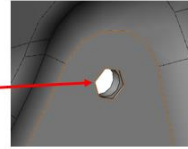

Hole #2: 6.35 Existing Hex Hole (outside view) for M6 -1.0 x 16mm bolt (item 1)

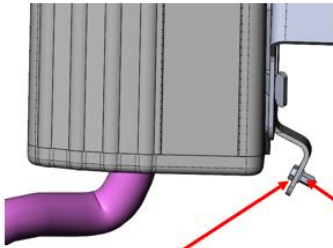

M6 x 1.0P x 16L bolt (item 1)

M6 x 1.0P flange nut (item 2)

M4 x 0.7P x 20L flanged button head socket cap bolt (item 13)

M4 x 0.7P UNut (item 4 in fastener list)

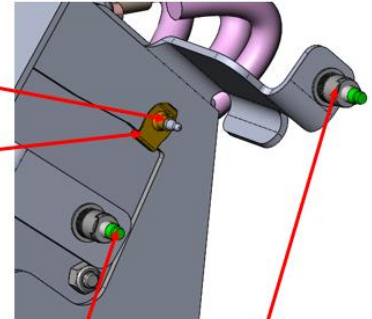

1. M4x0.7 Self-aligning Rivnut (item 6) McMaster 93669A140
2. M4x0.7 x 20 bolt (item 3)
3. M4 washer (item 5)

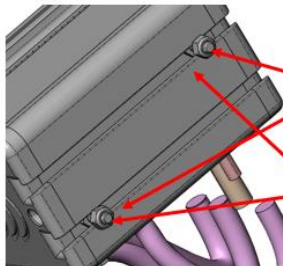

Qty 2, M6 x 1.0P x 16L bolt (item 1)

Qty 2, M6 x 1.0 flange nut (item 2)

1. M4x0.7 Self-aligning Rivnut (item 6) McMaster 93669A140
2. M4x0.7 x 20 bolt (item 3)
3. M4 washer (item 5)

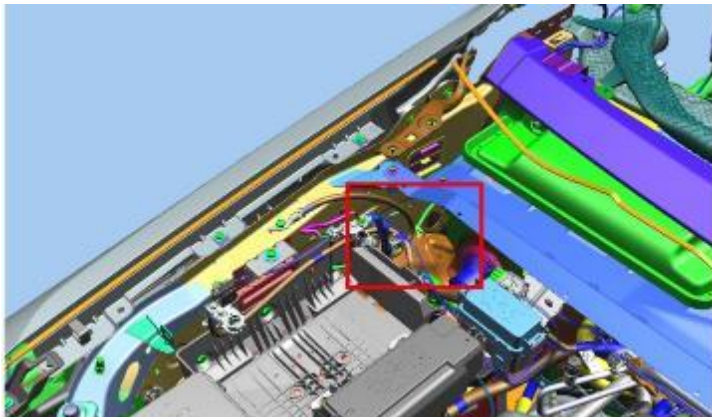

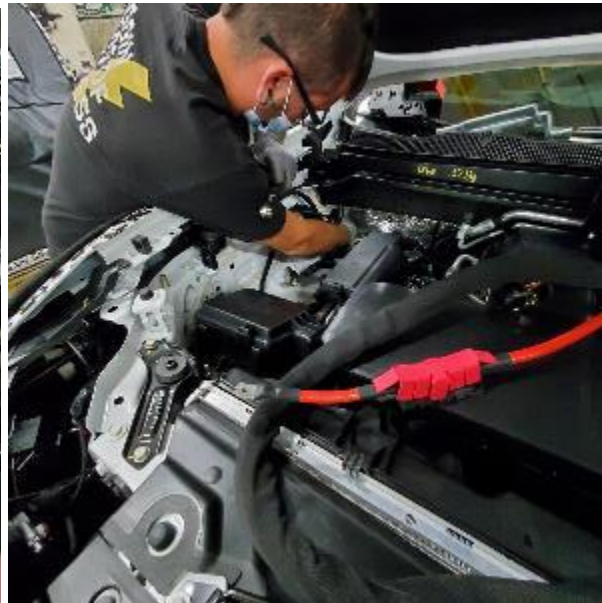

4. Attach flat mounting backplate to controller slotted face with two M6 x 1.0P x 16L bolts (item 1)
 - a. Slide one M6 x 1.0P x 16 bolt (item 1) into each of the two slots on the winch controller housing.

- b. Orient flat mount plate as shown with extended tab opposite the face with wire harness. Shift the mount plate so the top flat edge is even with the top of the winch controller (see pictures)
- c. Secure the flat mount plate with a M6 x 1.0 flange nut (item 2) on each of the two bolts



Bolt locations in controller t-slot for backplate

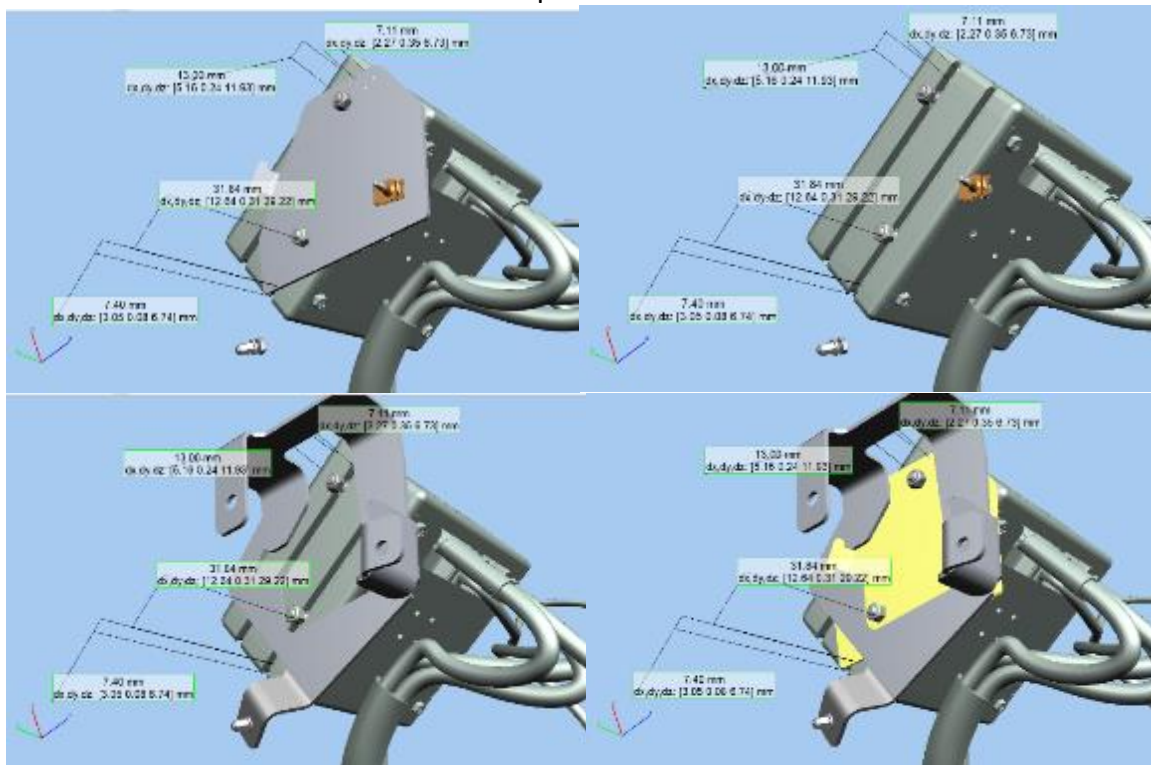

5. Screw the control module and plate assembly to the 3 legged wall mount bracket
 - a. Remove the M4 x 0.7P x 20L flanged button head bolt (item 13) from the Unut in the 3-legged wall mount plate.
 - b. Slide the flat mount plate tab secured to the winch control module into the slotted opening on the 3-legged wall mount bracket.
 - c. Screw the M4 x 0.7P x 20L flanged button head bolt (item 13) through the hole on the flat mount plate into the Unut on the 3-legged wall mount bracket (see pictures below).



D. IRAP (Ignition Retained Accessory Power) Wire Installation and ON/OFF Switch Wire Installation (as appropriate) in Passenger Foot Compartment Area

1. If an Accessory Power Box (see picture below) is NOT installed in the vehicle complete all steps in this section (Reference Service Information - Document ID: 6058122 [Document ID: 6058122 \(gm.com\)](http://www.gm.com) starting at Step 16). Otherwise, if the Accessory Power Box (see picture below) IS installed in the vehicle proceed to the next section 2.

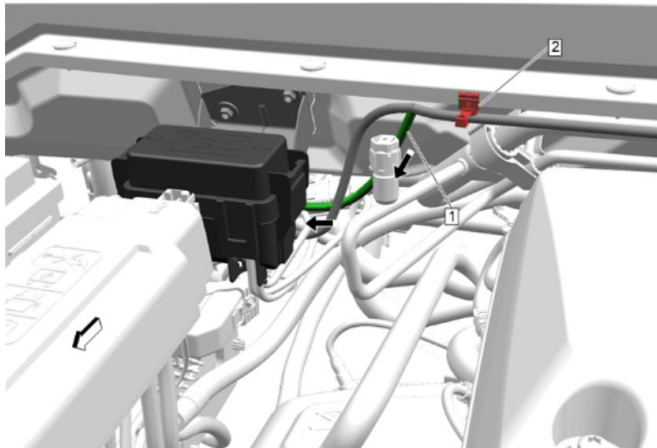

- a. From inside the vehicle on the passenger side below the instrument panel, locate the wire harness grommet (1).

Caution: Always check position of hole before drilling. Failing to do so may cause damage to the vehicle, misalignment of components or the inability to install the accessory.

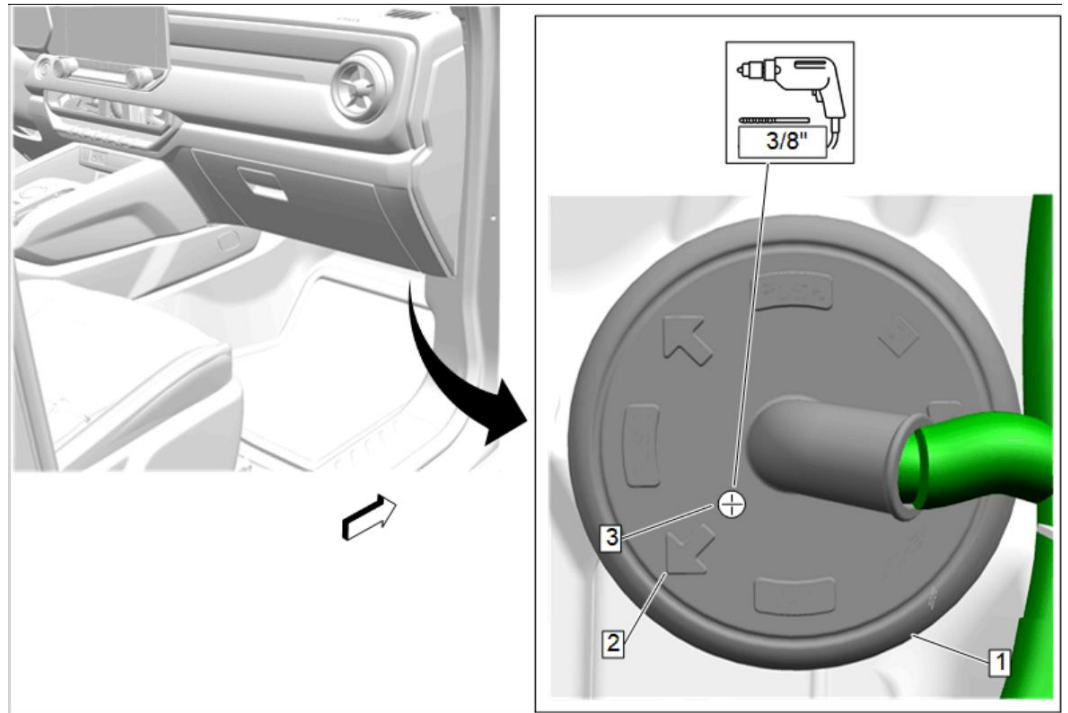

- b. Poke a hole (3) aligned with the arrow (2) using a straight pick (pictured below) through the inside and outside grommet (1) making sure to keep it centered between the grommet's outer edge and the wire bundle to avoid damage to the grommet. (A drill with 3/8" bit can be used as an alternative method).

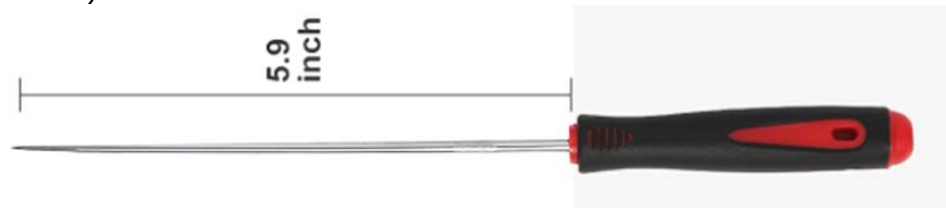

- c. Using the pick as a fish tool (or replace with a longer fish tool if preferred), leave it in the grommet hole (3) and locate it underhood.
- d. As determined in Step A for the winch on/off switch execution:
1. **WHEN the Center Console Auxiliary Switch will be used** as the winch on/off switch then:
 - a. Tape the shorter red winch controller IRAP wire end without terminal AND the long (2040 mm) Black 18 AWG wire originating from the control module together at the end of the red wire. Then tape the long end of the black wire to the end of the pick tool (fish/hook tool optional) and pull through the grommet (2) into the interior taking up excess length and assuring it does not get bound up. **Important:** Seal where wire enters the grommet on both inboard and outboard

engine side with waterproof silicone sealant or equivalent to prevent leaks.

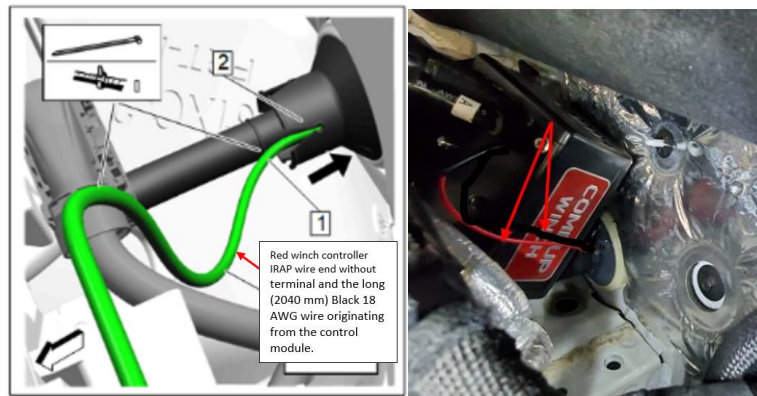
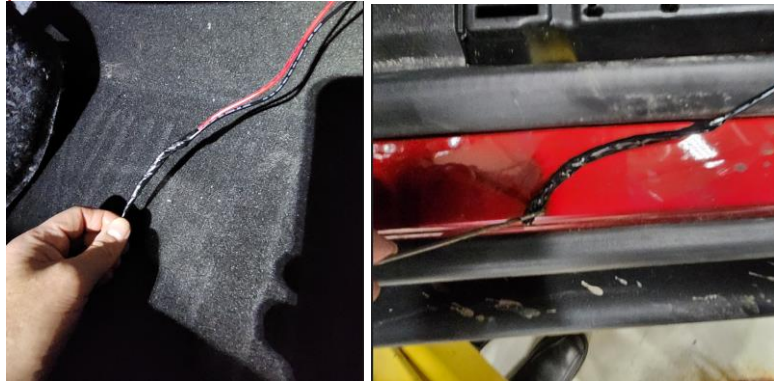

2. **WHEN** the 3-gang switch installation – GM PN 84938259 will be used as the winch on/off switch then:

- a. Tape **ONLY** the **Red winch controller IRAP wire end without terminal** to the end of the pick tool (fish/hook tool optional) and pull through the grommet (2) into the interior taking up excess length and assuring it does not get bound up.

Important: Seal where wire enters the grommet on both inboard and outboard engine side with waterproof silicone sealant or equivalent to prevent leaks.

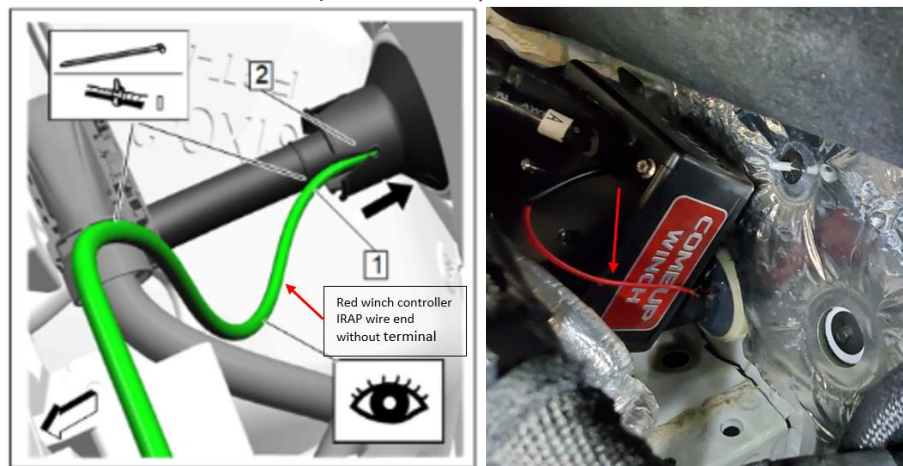

- e. On the front passenger interior side of vehicle, remove the front side door sill garnish molding. Refer to [Front Side Door Sill Garnish Molding Replacement](#) in Vehicle Service Manual.
- f. Locate the Red winch controller IRAP wiring passed through the grommet by the passenger floor area (and if present the long (2040 mm) Black 18 AWG

wire originating from the control module). Remove wire(s) from the pick tool (optional 2' long fish/hook tool).

- g. Remove the instrument panel lower trim panel insulator. Refer to [Instrument Panel Lower Trim Panel Insulator Replacement](#) in Vehicle Service Manual.



- h. Locate the interior electrical center (1) and remove it from the bracket (3) by depressing the tab (2).

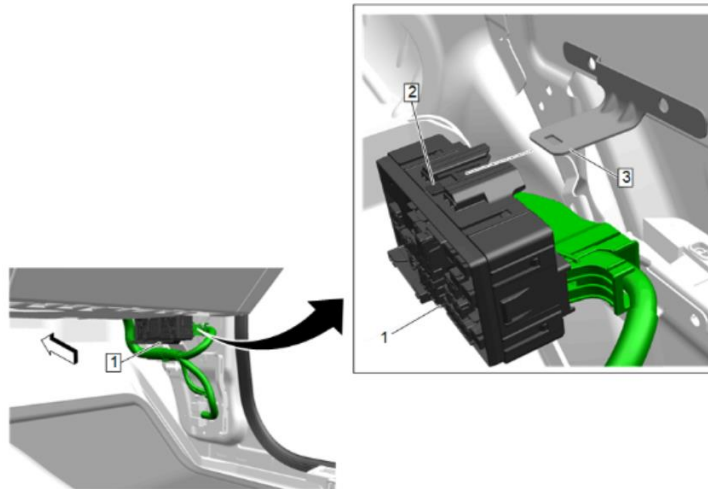

- i. Locate the 12-way connector (1) and remove it from the back of the interior electrical center (2) by disengaging the CPA (3) and pinching tab with a pull motion.

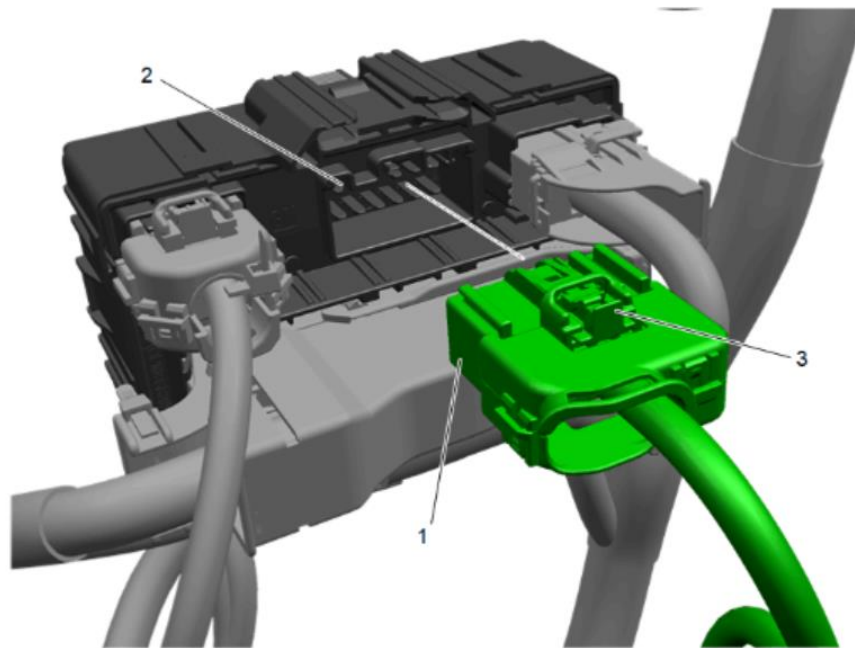

- j. Remove the 12-way connector cover (1) by disengaging tabs to gain access to back of connector. If present remove the zip tie on the cover to allow removal.

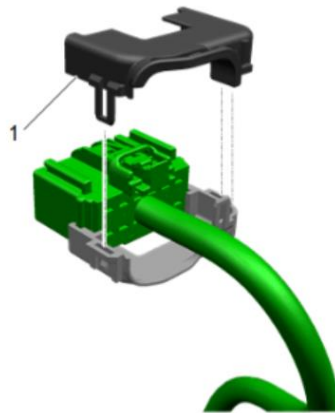

- k. Unlock the orange terminal lock (TPA) (1) of the 12-way connector.

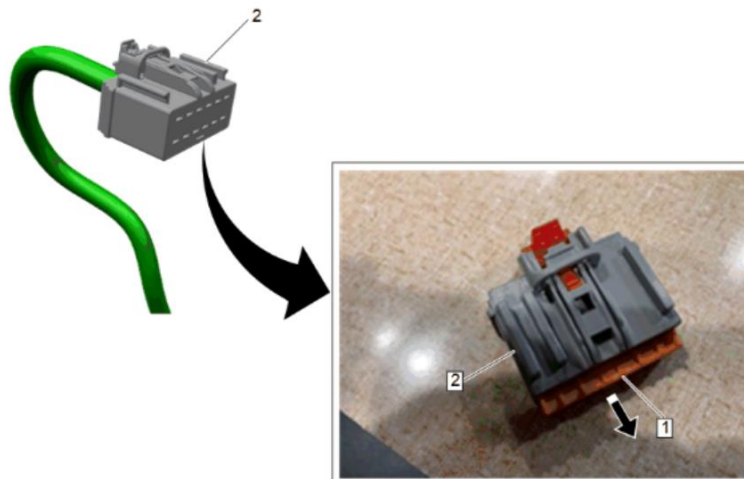

- l. Locate and populate the single Red wire with metal terminal (1) from the winch kit (item 14 in controller fastener kit list) into cavity 3 of 12-way connector. The connector tabs must be facing the top of the 12-way connector housing.

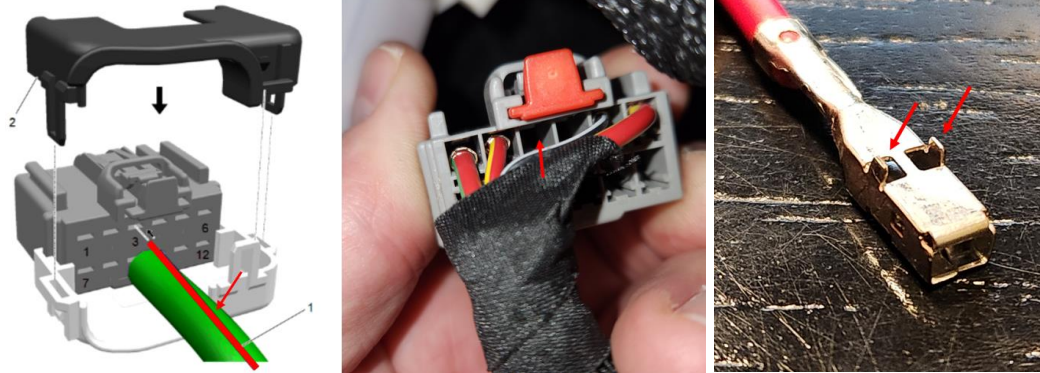

- m. Relock the orange terminal lock (TPA) of the 12-way connector and reseal the connector cover (2) that was removed to access the back. Install a zip tie on the cover to retain the two cover halves together.

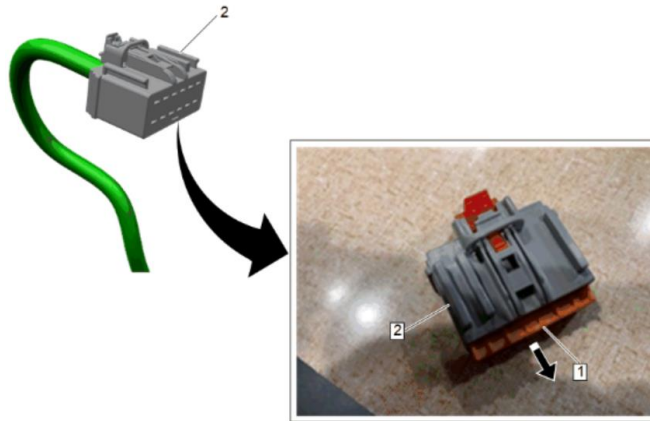

- n. Route red IRAP wire along the wiring break-out and tape about 50 mm from back of 12-way connector assembly (1) so it does not get damaged.

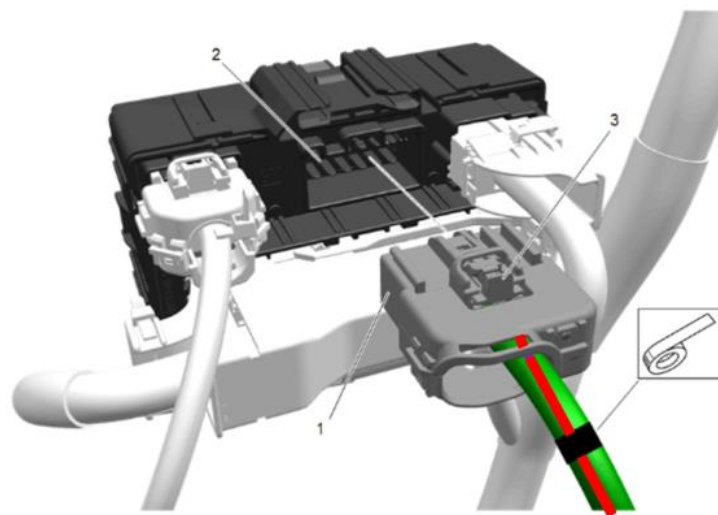

- o. Re-attach the 12-way connector (1) to the interior electrical center (2) and lock the red CPA (3).
- p. Re-attach the interior electrical center to the bracket.

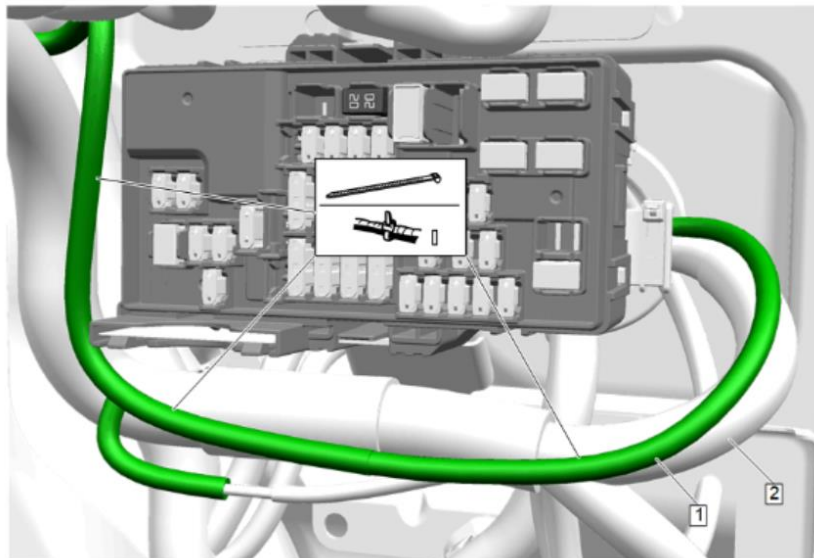

- q. Splice the Red wire from the 12-way connector to its mating Red IRAP wire that was fished through grommet with splices supplied (item 9 on the controller fastener kit list). Refer to [Wire to Wire Repair](#) in Vehicle Service Manual.

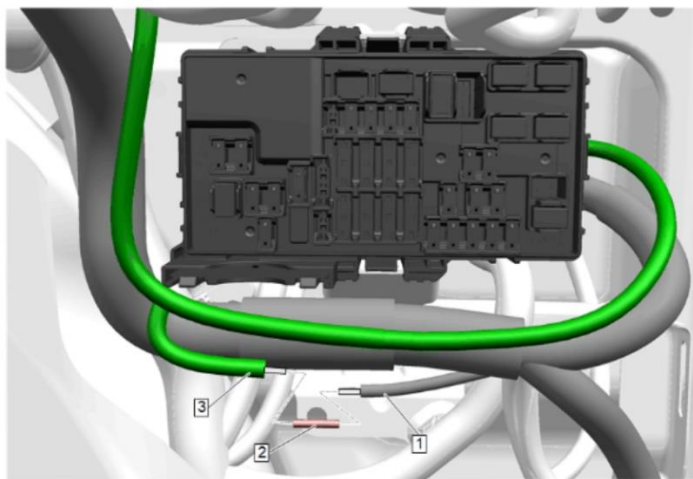

- r. Install the Blue 20A M-Case fuse (1) supplied in the winch kit (item 8 in the controller fastener kit list) to location F23 of the interior electrical center. Tilt the fuse box 45 degrees from horizontal to ensure the fuse is securely seated and does not fall out.

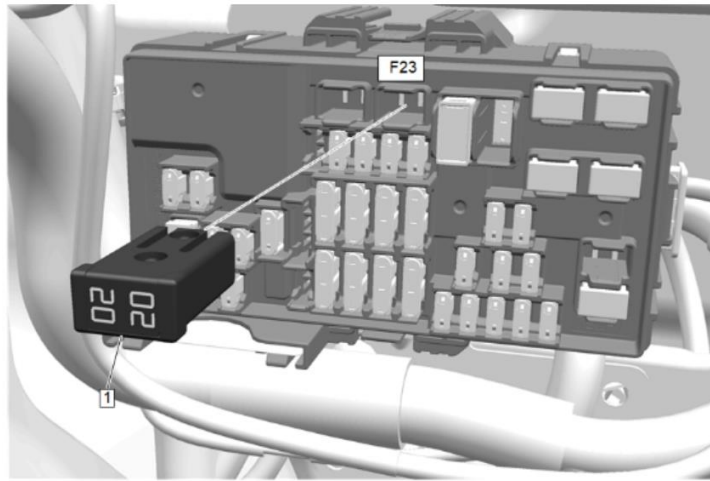

- s. WHEN the Center Console Auxiliary Switch will be used as the winch on/off switch then:

1. Locate the blunt cut blue/white wire in the main harness.
2. Route the long (2040 mm) Black 18 AWG wire originating from the control module to the blue/white wire in the main harness. Cut the long black 18 AWG wire allowing at least 6 inches of extra length, to allow ample length to butt splice the black wire to the blue/white wire.
3. After stripping wire insulation off the ends butt splice the blue/white and black wires together and crimp the splice. Refer to [Wire to Wire Repair](#) in Vehicle Service Manual.

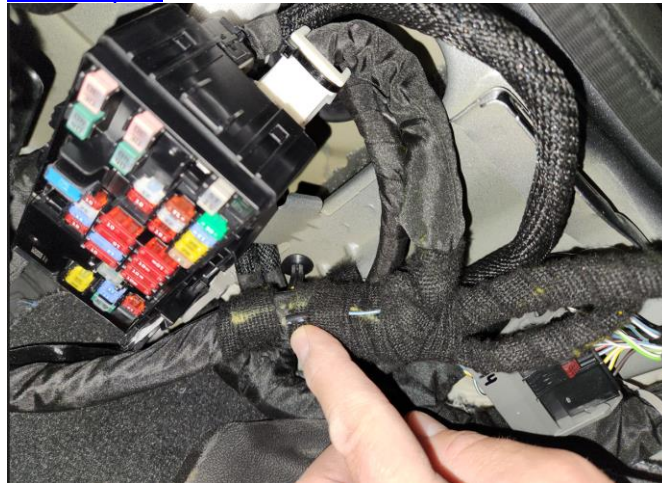

- t. Secure the fused harness (1) to the main harness (2) with tie straps in areas shown. Trim excess off tie straps.

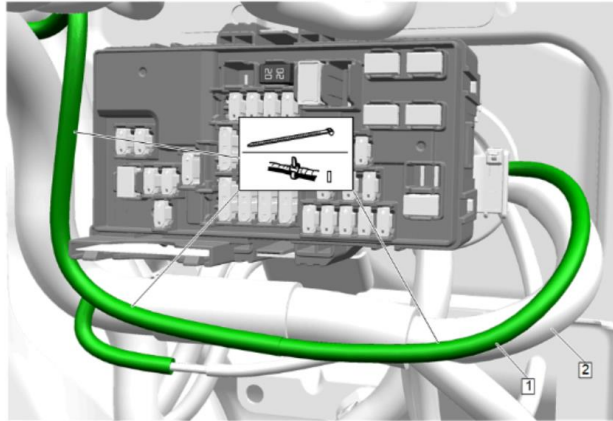

- u. Reinstall the instrument panel lower trim panel insulator. Refer to [Instrument Panel Lower Trim Panel Insulator Replacement](#) in Vehicle Service Manual.
 - v. Reinstall the front side door sill garnish molding. Refer to [Front Side Door Sill Garnish Molding Replacement](#) in Vehicle Service Manual.
2. If the Accessory Power Box (see picture below) IS already installed in the vehicle, then complete the following steps.

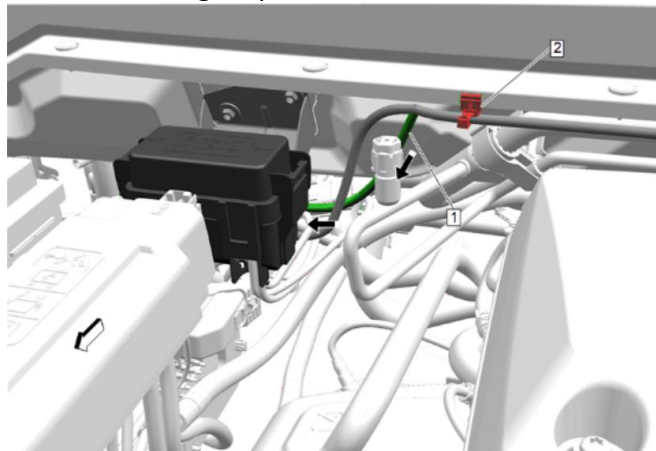

- a. From inside the vehicle on the passenger side below the instrument panel, locate the wire harness grommet (1).

Caution: Always check position of hole before drilling. Failing to do so may cause damage to the vehicle, misalignment of components or the inability to install the accessory.

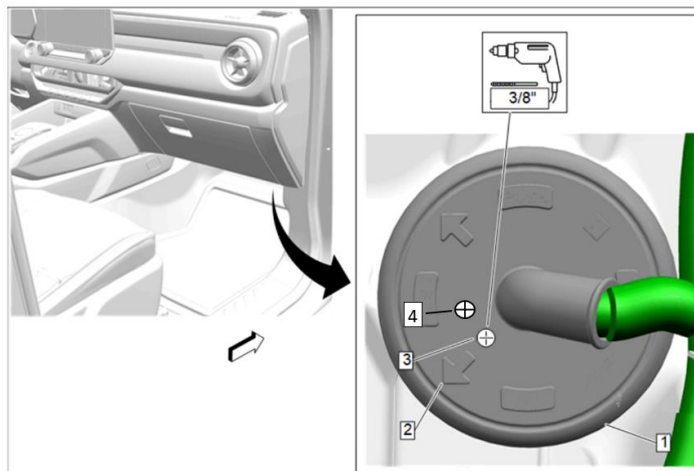

- b. Poke a hole (4) just below the 9 o'clock position using a straight pick (pictured below) through the inside and outside grommet (1) making sure to keep it centered between the grommets outer edge and the wire bundle to avoid damage to the grommet. (A drill with 3/8" bit can be used as an alternative method). An existing wire bundle from the Accessory Power Box will already be routed through the grommet (1) at hole location (3).

Caution: Be careful not to angle pierce or drill toward the main wire bundle as damage could occur. Be careful not to pierce or drill the Accessory Power Box IRAP wire that has already been installed.



- c. Using the pick as a fish tool (or replace with a longer fish tool if preferred), leave it in the grommet hole (4) and locate it underhood.
- d. As determined in Step A for the winch on/off switch execution:
1. **WHEN the Center Console Auxiliary Switch will be used** as the winch on/off switch then:
 - a. Tape the shorter red winch controller IRAP wire end without terminal AND the long (2040 mm) Black 18 AWG wire originating from the control module together at the end of the red wire. Then tape the long end of the black wire to the end of the pick tool (fish/hook tool optional) and pull through the grommet (2) into the interior taking up excess length and assuring it does not get bound up. **Important: Seal where wire enters the grommet on both inboard and outboard engine side with waterproof silicone sealant or equivalent to prevent leaks.**

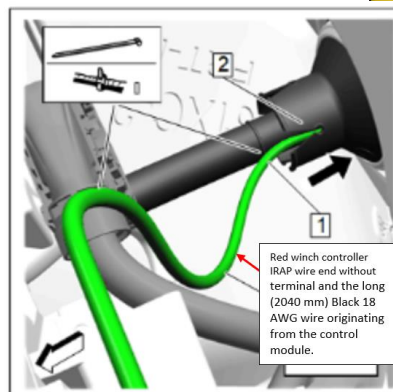
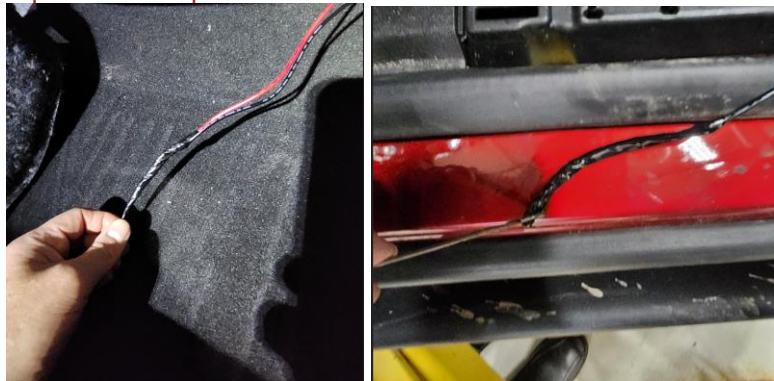

2. **WHEN the 3-gang switch installation – GM PN 84938259 will be used as the winch on/off switch then:**

- a. Tape **ONLY the Red winch controller IRAP wire end without terminal** to the end of the pick tool (fish/hook tool optional) and pull through the grommet (2) into the interior taking up excess length and assuring it does not get bound up.

Important: Seal where wire enters the grommet on both inboard and outboard engine side with waterproof silicone sealant or equivalent to prevent leaks.

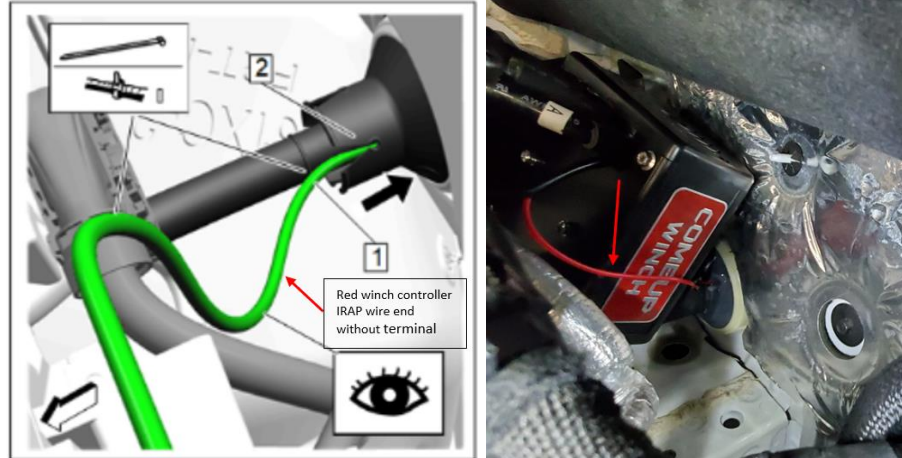

- e. On the front passenger interior side of vehicle, remove the front side door sill garnish molding. Refer to [Front Side Door Sill Garnish Molding Replacement](#) in Vehicle Service Manual.
- f. Locate the Red winch controller IRAP wiring passed through the grommet by the passenger floor area (and if present the long (2040 mm) Black 18 AWG wire originating from the control module). Remove wire(s) from the pick tool (optional 2' long fish/hook tool).
- g. From the Violet wire to Violet wire splice location measure 2 inches closer to the 12-way connector assembly (1). At the 2-inch mark cut the Violet wire. Remove 3/8th of an inch of the plastic wire covering at the end of the cut Violet wire, and also the Red winch controller IRAP wire.

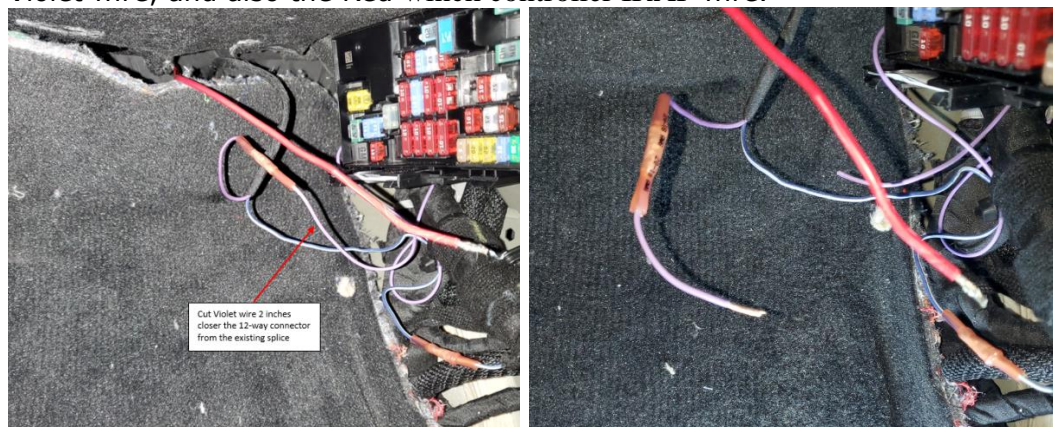

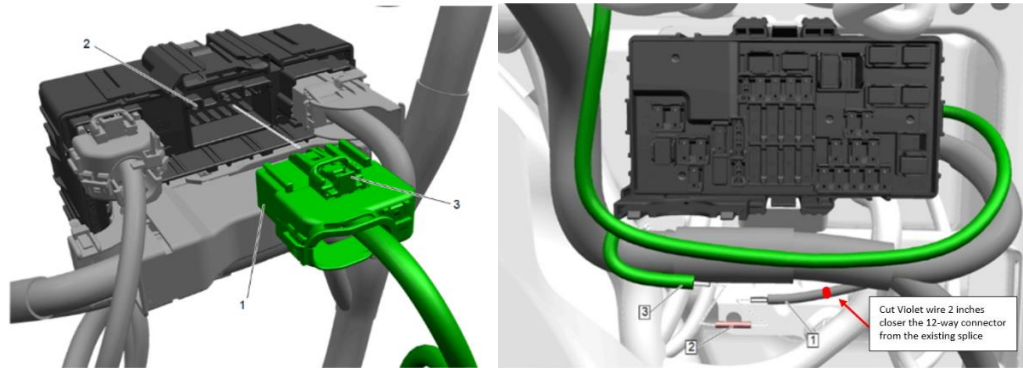

- h. Twist the cut end of the Violet wire closest to the existing splice together with the Red winch controller IRAP wire end. Place them together into one end of the provided splices (tip: twist the butt splice onto the two Red and Violet connected wires) and crimp the splice. Refer to [Wire to Wire Repair](#) in Vehicle Service Manual.

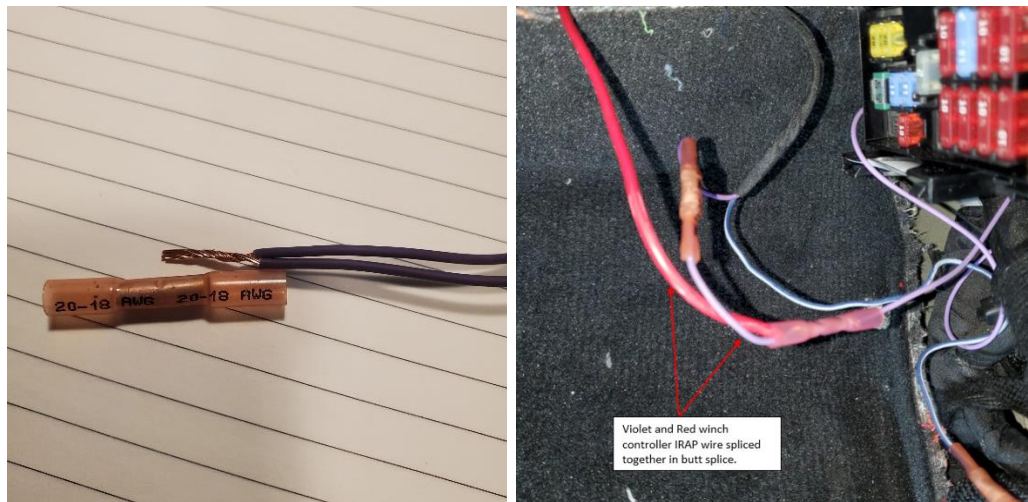

- i. Place the remaining end of the Violet wire closest to the 12-way connector in the other end of the butt splice and crimp the splice.
- j. **WHEN the Center Console Auxiliary Switch will be used as the winch on/off switch then:**
1. Locate the blunt cut blue/white wire in the main harness.
 2. Route the long (2040 mm) Black 18 AWG wire originating from the control module to the blue/white wire in the main harness. Cut the long black 18 AWG wire allowing at least 6 inches of extra length, to allow ample length to butt splice the black wire to the blue/white wire.
 3. After stripping wire insulation off the ends butt splice the blue/white and black wires together and crimp the splice. Refer to [Wire to Wire Repair](#) in Vehicle Service Manual.



- k. Secure the fished harness (1) to the main harness (2) with tie straps in areas shown. Trim excess off tie straps.

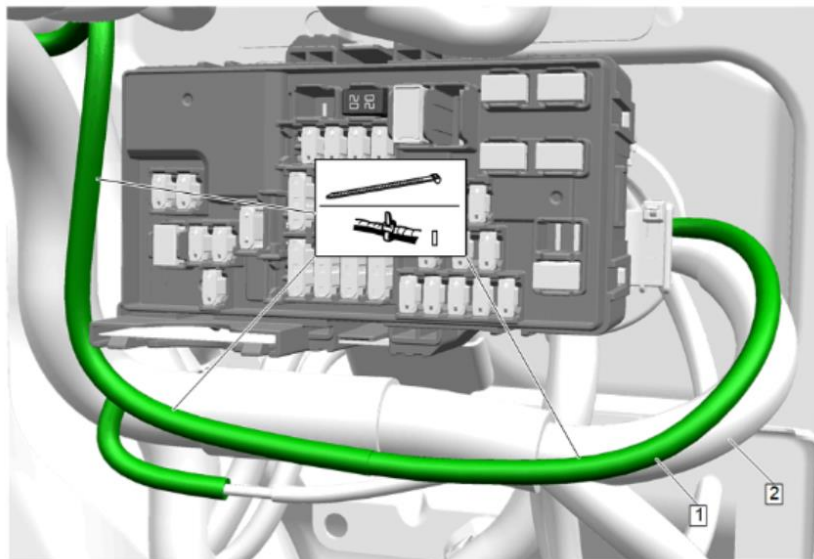

- l. Reinstall the front side door sill garnish molding. Refer to [Front Side Door Sill Garnish Molding Replacement](#) in Vehicle Service Manual.

E. Winch Controller Power Cable and Mega fuse holder bracket Installation

- 1. If present reinstall the Accessory Wiring Junction Box to its mounting bracket (See Service Information - Document ID: 6058122 [Document ID: 6058122 \(gm.com\)](#) step 13).
 - a. Align the slots (2) on the relay box (1) to the blades (3) on the bracket and push the relay box downward onto bracket until it is secure.

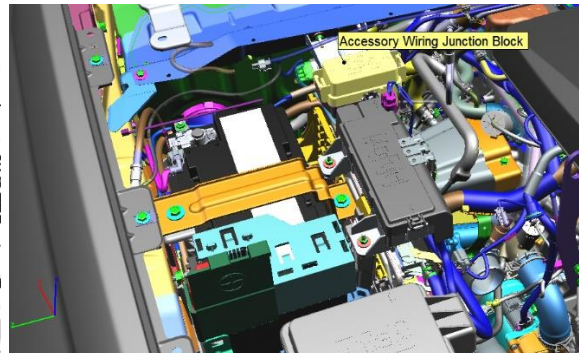
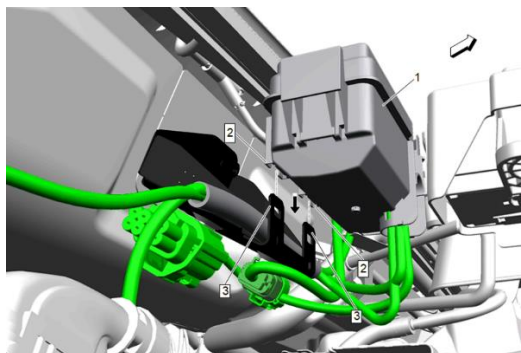

2. Reinstall the battery assembly and the battery tray. Do not install the battery cross brace (See Service Information - Document ID: 6142605 [Document ID: 6142605 \(gm.com\)](http://gm.com)).
3. If the Accessory Wiring Junction Box is NOT already installed do the following:
 - a. At the positive battery terminal mark the red protective cover (1) as pictured here. Cut out the inside portion of the marked area (2) as little as necessary, to provide bolt access to the winch power cable terminal once it is installed later in the process.



4. Install the positive battery terminal and negative battery terminal to the battery.
5. Install 4 M4 x 0.7P UNuts (item 4 in controller fastener list) into the mega fuse holder bracket (see picture below).



6. Place the battery cross brace into position, without securing the two bolts. Place the mega fuse holder bracket on top of the battery cross brace. Next, secure both the battery cross brace and mega fuse holder bracket with the two battery cross brace bolts.

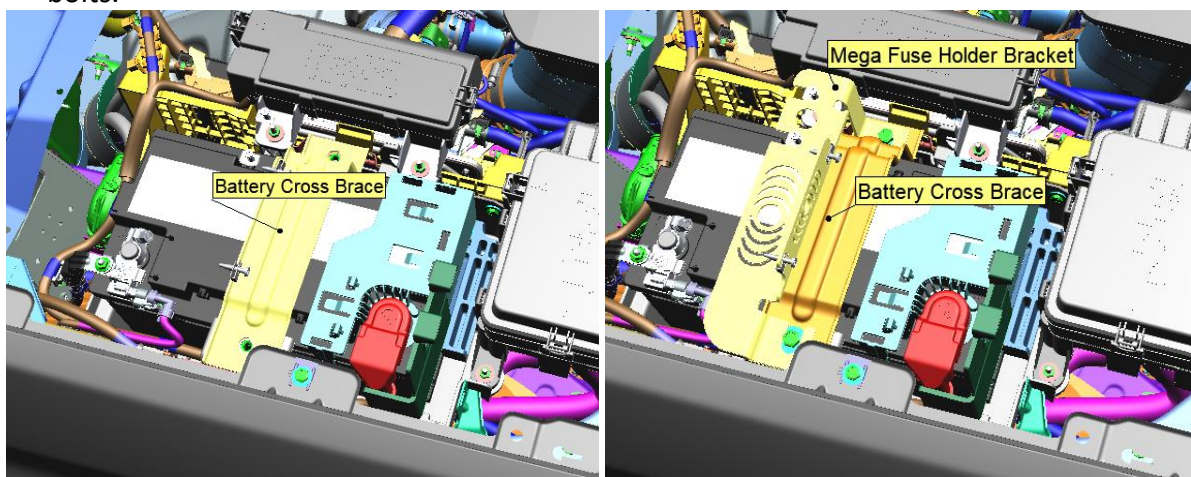

7. Route the winch power cable with mega fuse from the winch control module to the inboard side of the battery. Continue across the battery in front of the mega fuse holder bracket from the inboard to outboard side.

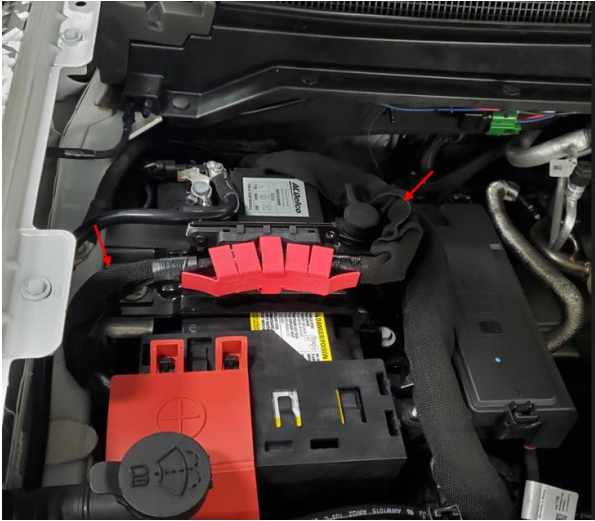

8. Attach the mega fuse holder into to the mega fuse holder bracket with two M4 x 0.7P x 20L flanged button head bolts (item 13 in the controller fastener list).

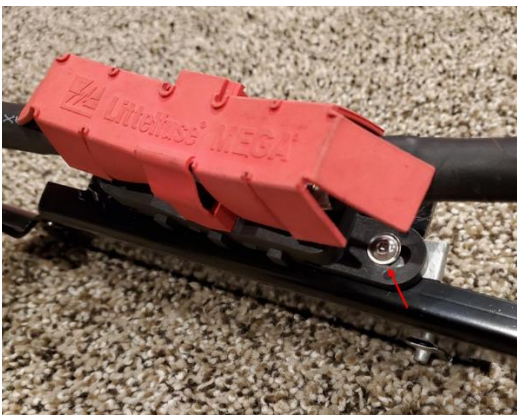

9. Later, at the end of the installation process following installation of the 3-gang switch, attach the winch power cable to the positive battery terminal.

F. Winch controller harness to winch routing & Wired Remote Plug Installation

1. Secure the wired remote plug in the mega fuse holder bracket at the inboard hole with two M4 x 0.7P x 20L flanged button head bolts (item 13 in the controller fastener list). Sandwich the rubber lid holder base between bracket top and plug flange bottom.

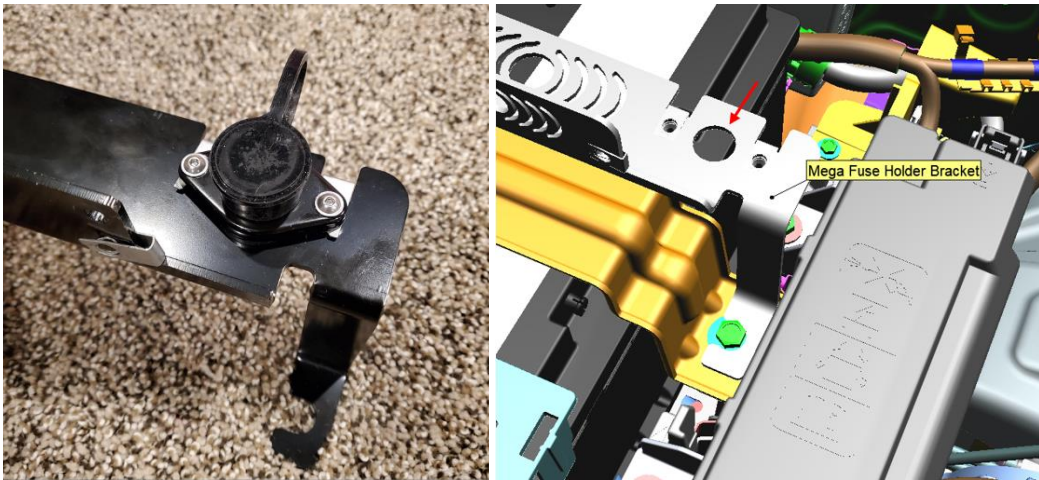

- Route the controller to winch harness bundle between the inboard battery edge and the outboard pre-fuse box (see picture). Zip tie the winch harness bundle and winch power cable together in the approximate location of the person's hand in the picture below. Use a 4.8 x 280 mm zip tie (item 11 in the controller fastener list).

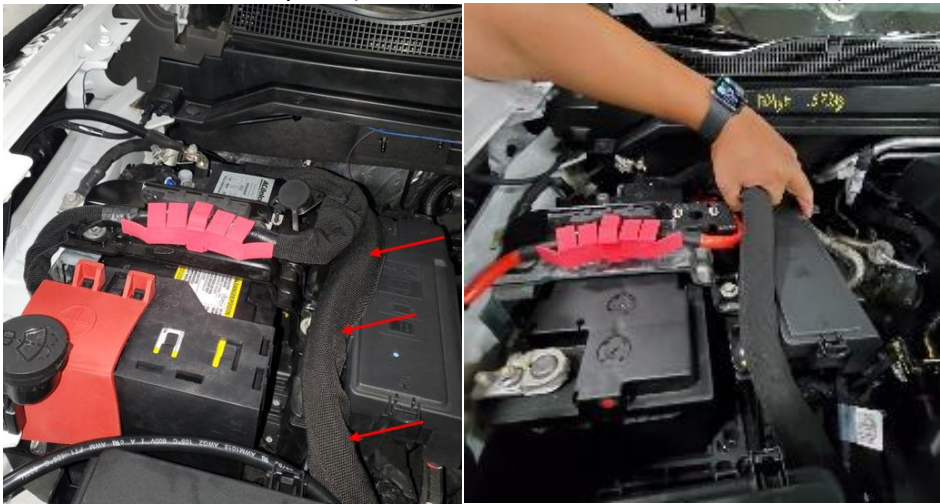

- Route winch harness bundle downward and inboard of the UEC located in front of the battery.

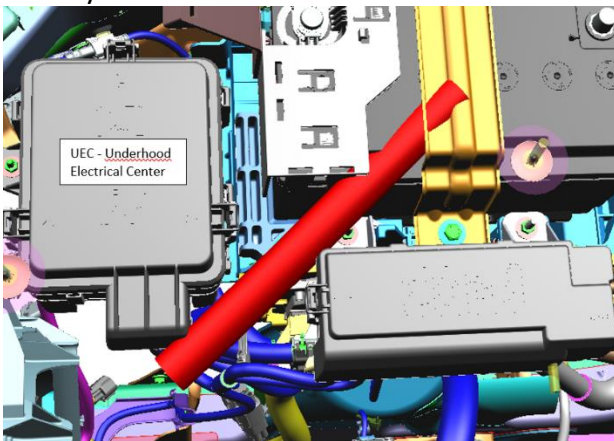

- Route winch harness bundle down from the UEC to the outer frame front passenger corner.

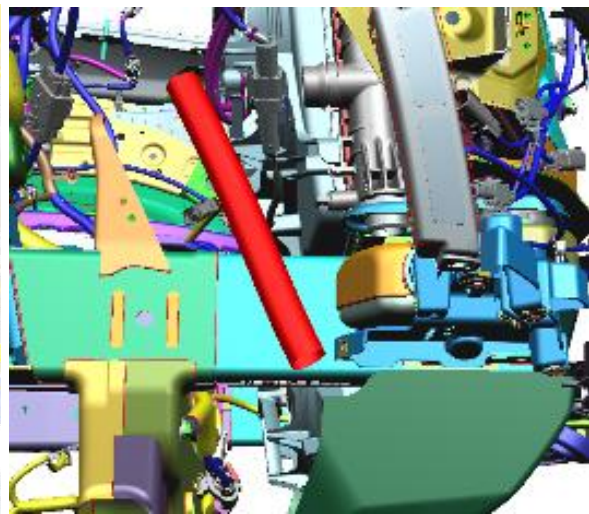
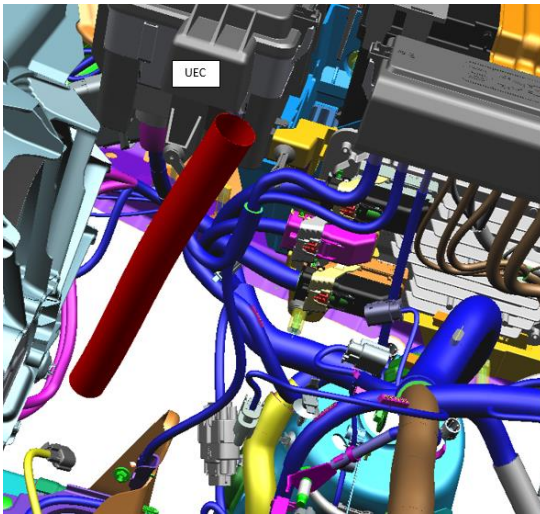

5. Route winch harness bundle across lower frame to driver side of truck.

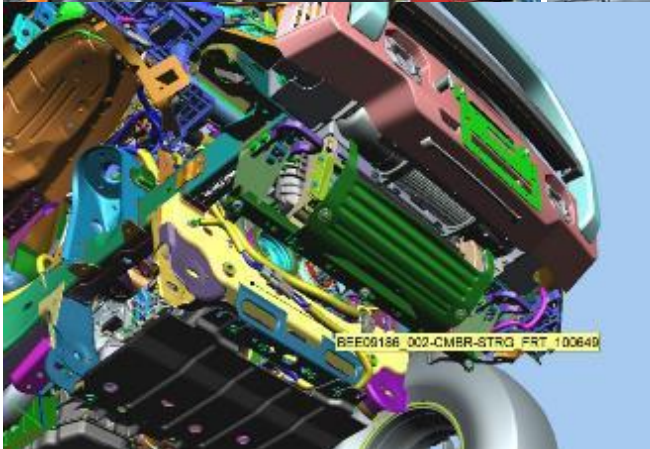
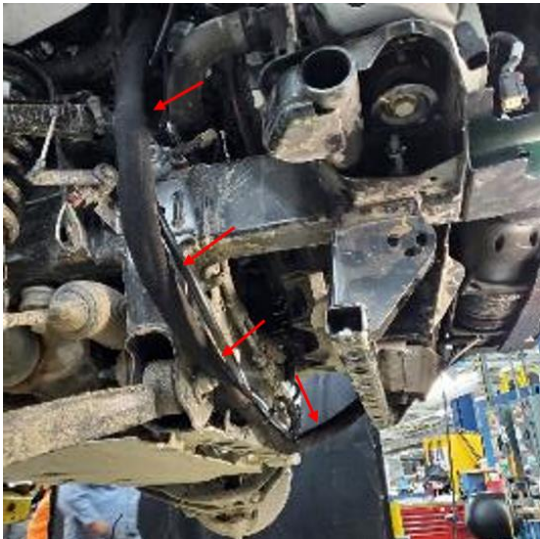

6. Route winch harness bundle forward toward winch. Route through the opening outboard of the Shutter assembly, inboard of the driver side FF COMP CMBR bracket, and above the horizontal square steel tube (CMBR-FF_COMP) for final connection to winch electrical terminals.

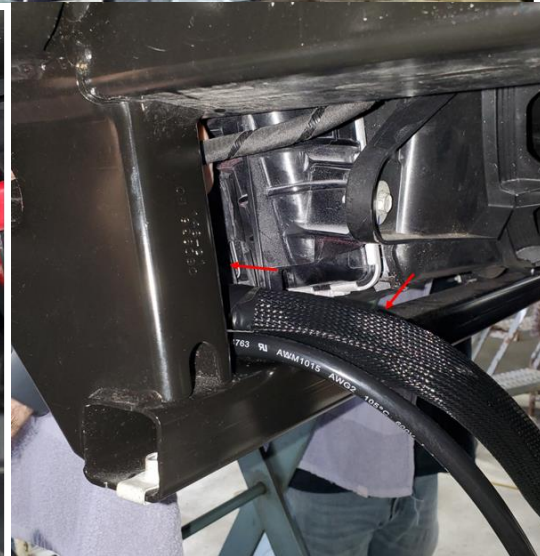
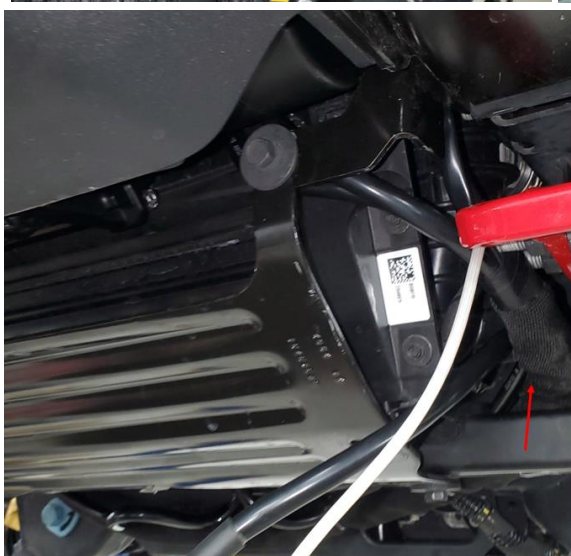
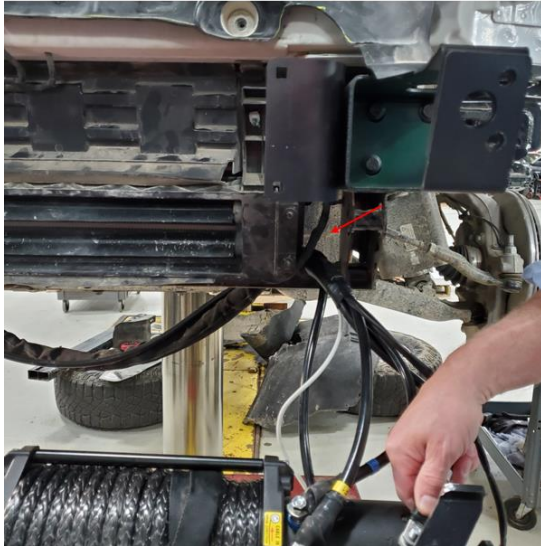
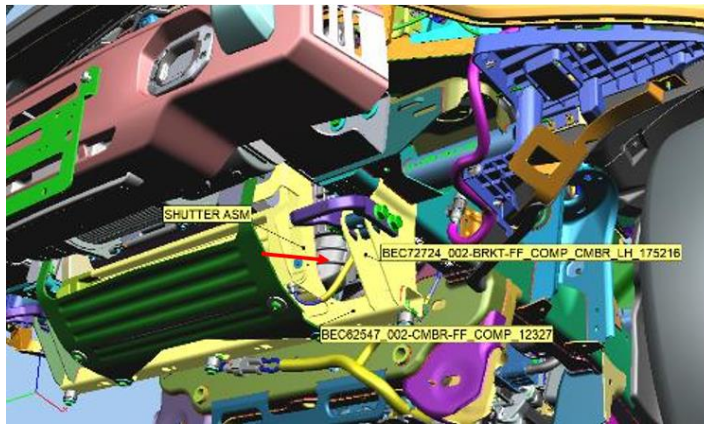

G. Chassis ground cable attachment(s) to battery ground

1. Unscrew the Chassis ground stud and threaded screw at the underhood front passenger corner of the frame rail. Double nest the two black 2AWG ground cable terminals under the threaded screw and ground stud and install to the frame rail.

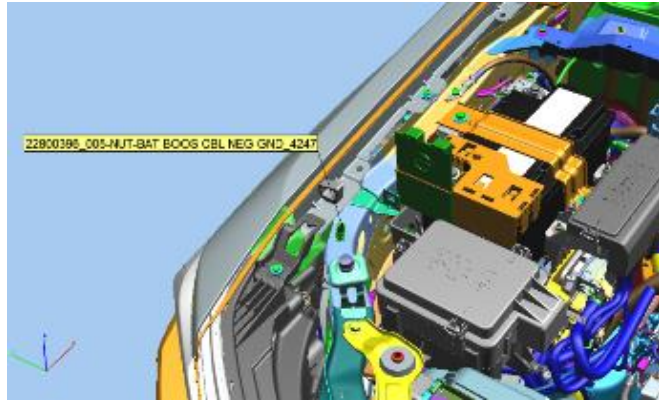

2. Route the shortest cable to the battery ground terminal along the frame rail. Do NOT attach the cable to battery ground until the end of the winch installation process.

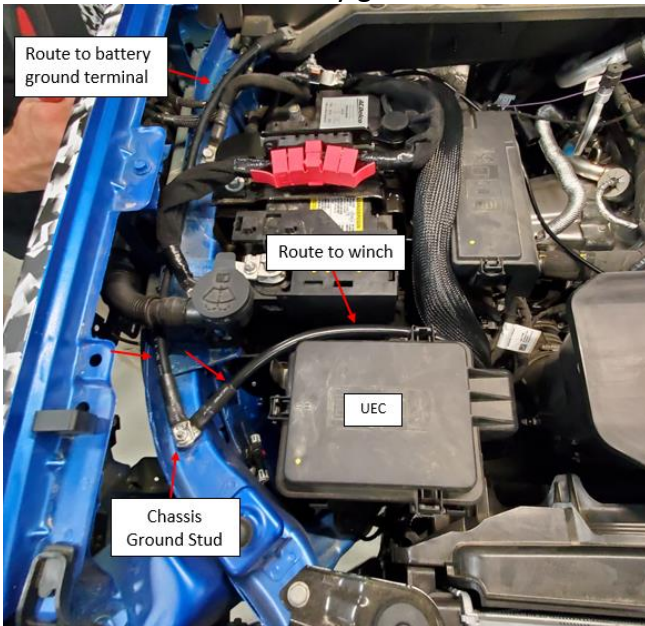

3. Route the longer black 2AWG cable from the chassis ground stud to the bottom winch ground stud along the same path as the winch controller to winch harness. Route the cable between the battery and UEC (see picture above). Then follow the winch controller harness down to the outer frame front passenger corner and across the lower frame to the truck driver side and winch ground stud.

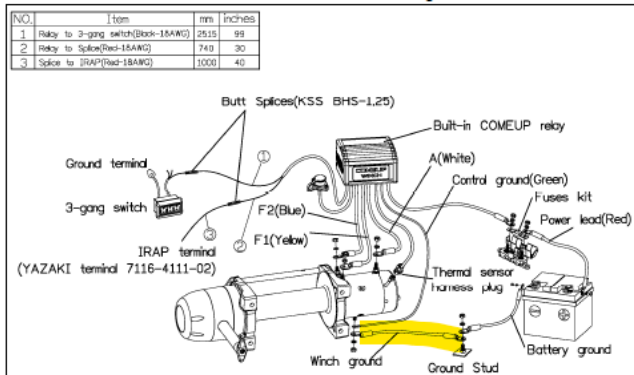

H. Install winch into Off-road Bumper Assembly

1. Remove the T-handle from the winch.

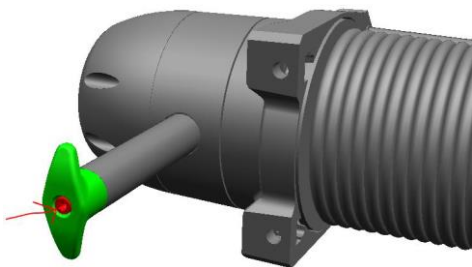

2. Remove off-road bumper fascia plug from the bumper fascia. **Retain the fascia plug for customer future use.** During off-road driving the T-handle should be removed to avoid damage. The bumper fascia plug should be reinstalled to avoid debris from entering the winch shaft threaded hole.

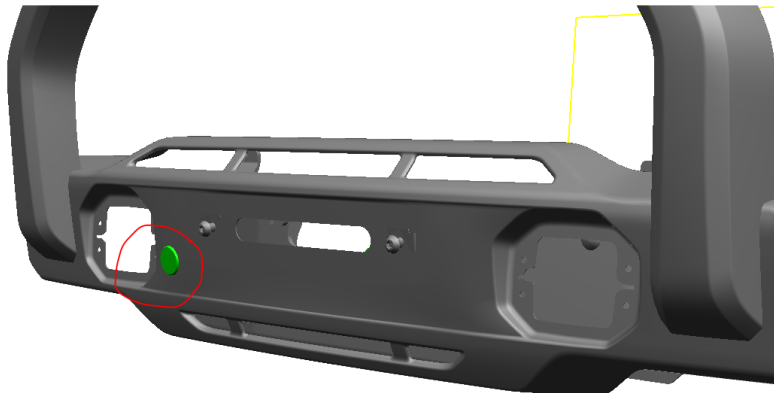

3. Set the winch on a flat surface with the winch feet and T-handle extension facing forward. Insert square nuts at 4 places in the winch mounting feet pockets. After inserting the 4 nuts place strip caulk or duct tape at the mount feet openings, to prevent the nuts from sliding out while installing the winch into the front bumper. **DO NOT** place strip caulk or tape on the bottom of the nut, as this will compromise the bolt torque allowing it to relax over time.

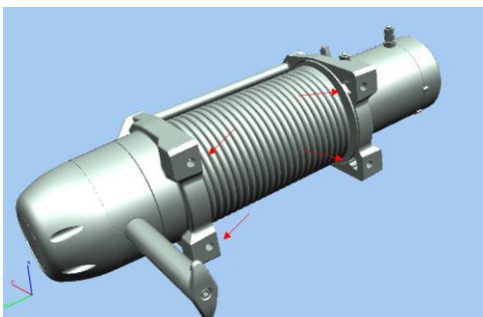

- Place the winch on a lift table (lift table GE-52200), with the winch mount feet facing forward. If a lift table is unavailable alternatively place the winch on a telescoping transmission jack. Do not install the winch in the bumper until directed to, after the winch electrical harnesses have been bolted to the winch terminals.



- Reconfirm that the winch harness bundle is routed inside the vertical passenger side bracket (BRKT-FF_COMP_CMBR_RH) (see screen shot below) and above the horizontal square steel tube (CMBR-FF_COMP) for final connection to winch electrical terminals. The skid plate will not re-install if the harness is not routed this way.

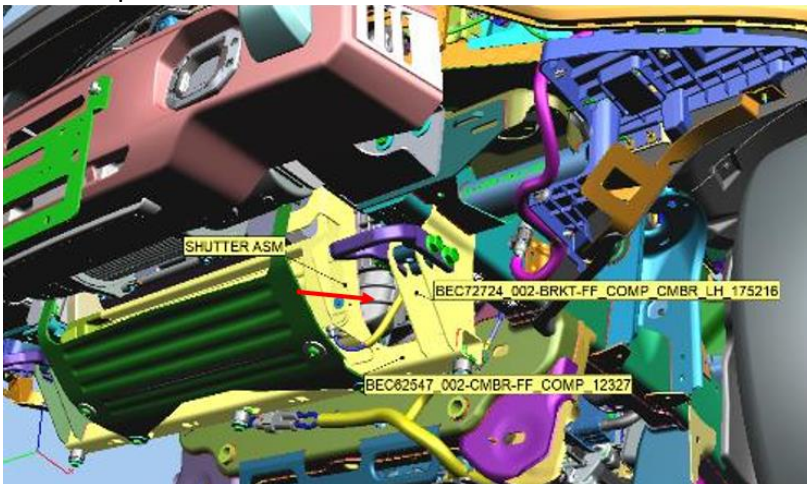

- Secure each of the winch harness electrical terminals to the top of the winch motor before lifting it into front bumper on the vehicle. **Do not secure harness terminals to the bottom of the winch motor in this step, as they will be secured after the winch is bolted into the bumper.** The winch will need to be moved close enough to the vehicle for the winch harness to reach the winch terminals. Bolt each of terminals to the corresponding color winch threaded studs by holding the lower nut on the stub and fastening the upper nut clockwise to a torque of 14 Nm. Include the lock washer on each threaded stud per the diagram shown here.
 - Bolt the blue, white, and yellow marked terminals to the same color marked bolts on the driver side top of winch. Ensure rubber boots (1) are installed over the studs.
 - Connect the plastic temperature sensor connector to its mating connector on the driver side top of winch.
 - Slide the control ground (white covered wire with eyelet from the winch controller wire harness bundle) then chassis ground to winch cable terminal (black cable connected to chassis ground stud near front of battery) onto the same stud on the driver side bottom of winch. Then, torque the bolt down.

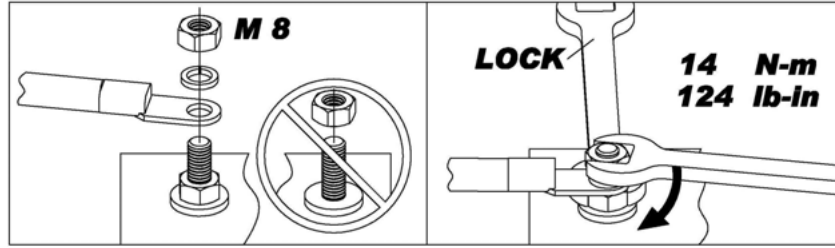
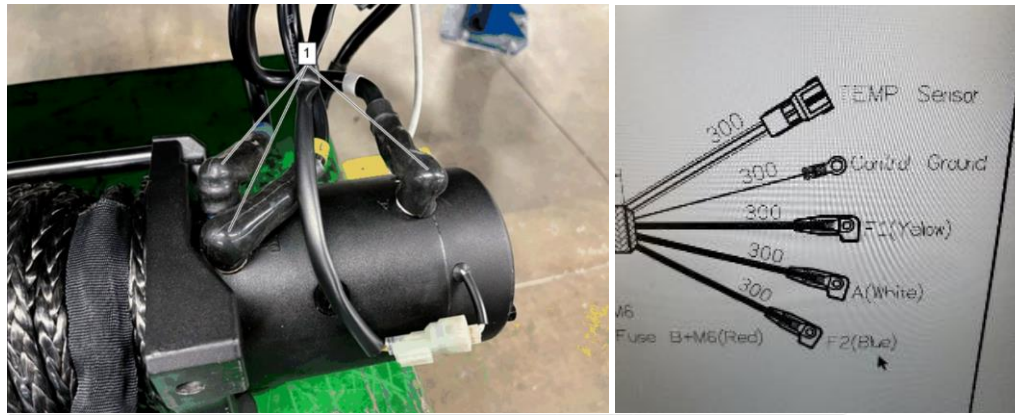

7. Route the winch rope through the bumper fairlead opening.
8. With help from an assistant, lift the winch (2) into position taking care not to scratch the winch T-handle shaft. Loosely install the top two winch mount bolts (1) » Loosely install [2x]

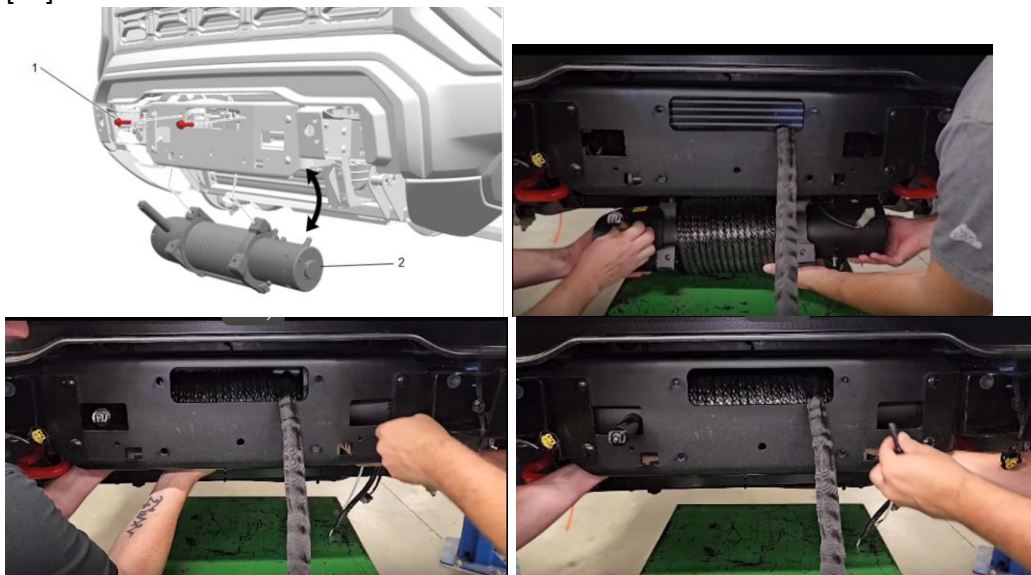

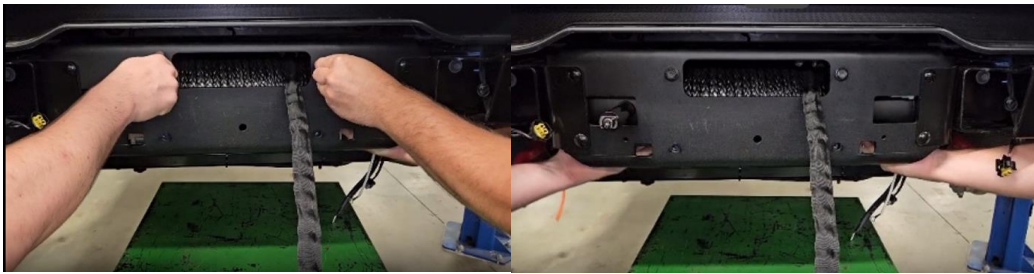

9. Reinstall the front winch bracket (3) with 4 bolts into the square nuts. Route the winch rope through the bumper fairlead opening. **Torque nuts to 58Nm with a torque wrench.**

- a. Winch Bracket Bolt (2) » Install and tighten [2x]
- b. Winch Bracket Bolt (1) » Tighten [2x]

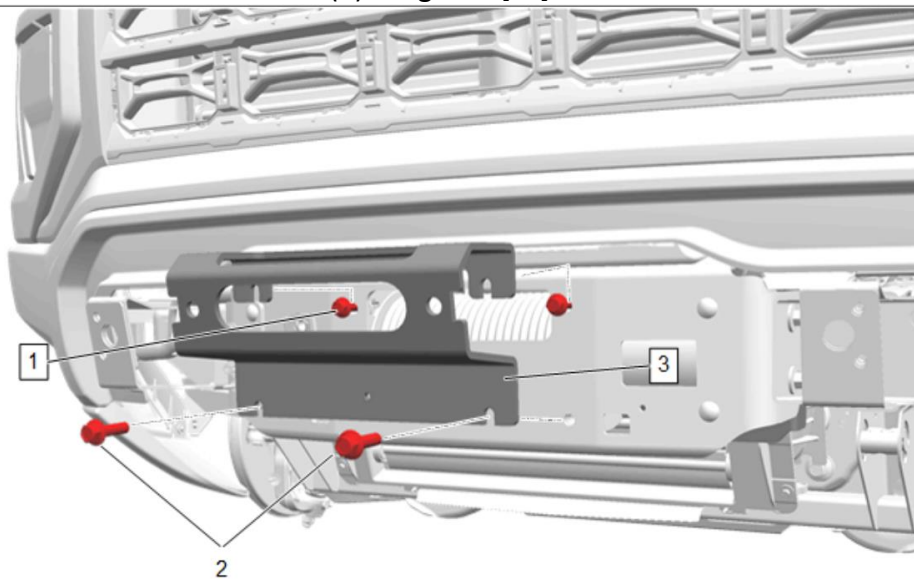

10. Install the control ground and chassis ground wire to the bottom of the winch motor.
 - a. Slide the control ground (white covered wire with eyelet from the winch controller wire harness bundle) then chassis ground to winch cable terminal (black cable connected to chassis ground stud near front of battery) onto the same stud on the driver side bottom of winch. Then, torque the bolt to 14 Nm.



11. Reinstall the L brackets by aligning the markings and tightening down the bolts. Torque nuts to 22 Nm.

- a. Winch Bracket - Left Side and Right Side (2) » Install [2x]
- b. Winch Bracket Nut - Left Side and Right Side (1) » Loosely install [4x]
- c. Align the grease / paint markings.
- d. Winch Bracket Nut - Left Side and Right Side (1) » Tighten [4x]

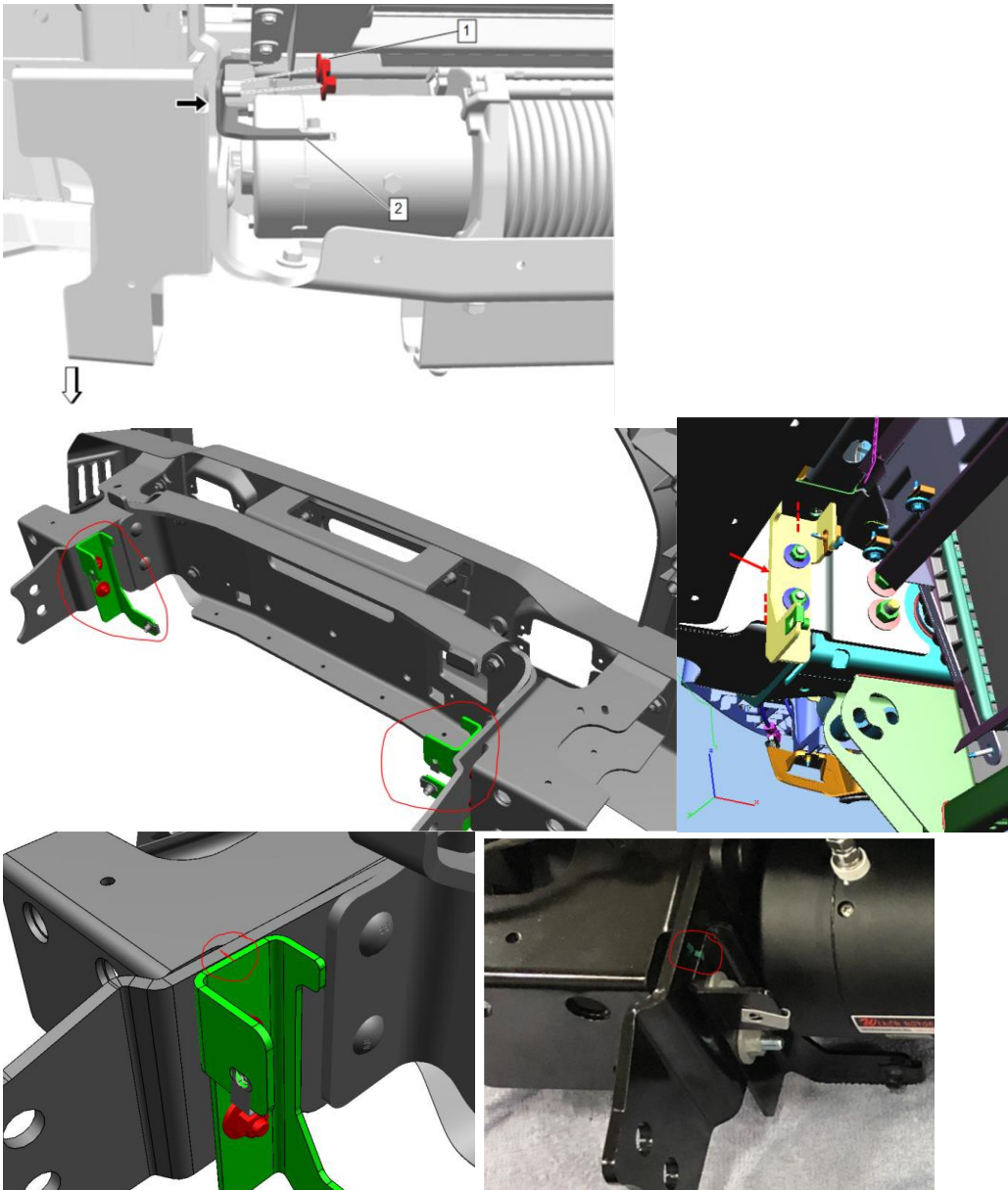

12. Reinstall the Front Bumper Lower Shutter (1). Ensure the winch harness is pushed upwards so shutter does not pinch the harness.
- a. Push the front bumper shutter up and bottom lip over the cross bar.
 - b. Front Bumper Lower Shutter (1) » Install
 - c. Connect the electrical connector.

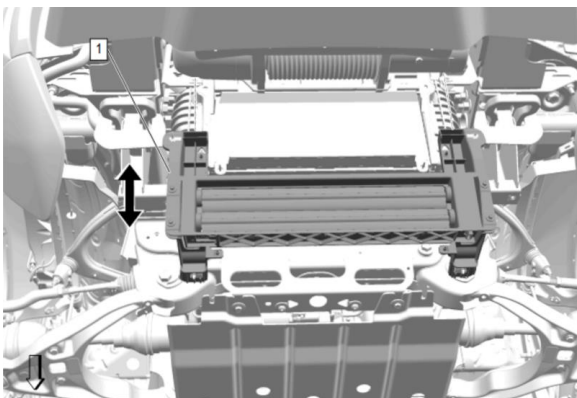

13. Reinstall the top and bottom active shutter assembly mounting bolts. Recommended to use electric ratchet for the top bolts. Torque fasteners to 2.5 Nm.
- a. Front Bumper Lower Shutter Bolt - Left Side and Right Side (1) » Install [4x]

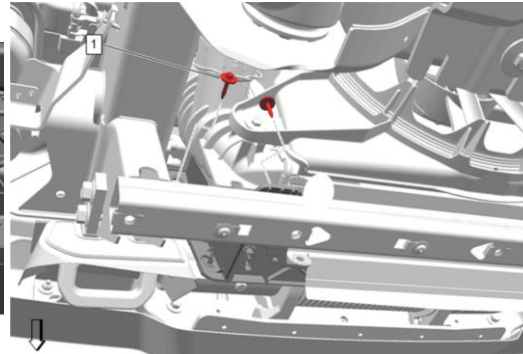
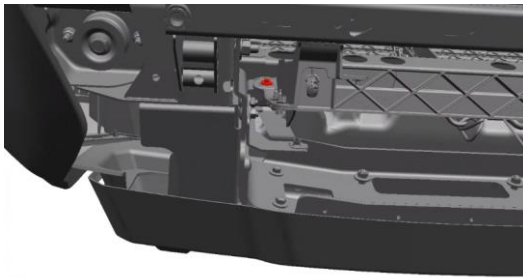

14. Reconnect the electrical connector to the shutter assembly.

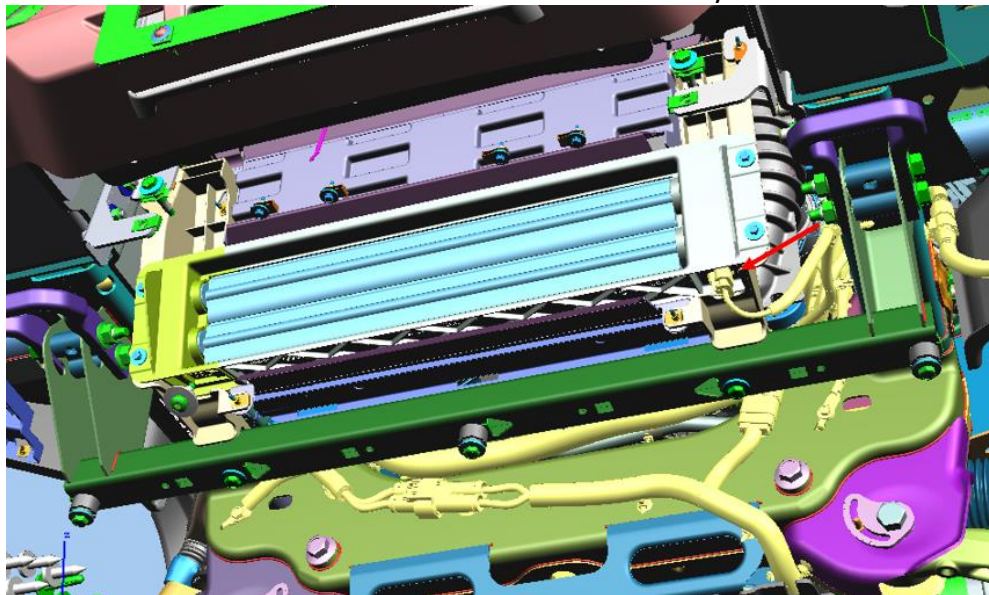

15. Reinstall the tow hooks. Tow hooks face down and bolts point inboard. Torque to 100Nm.

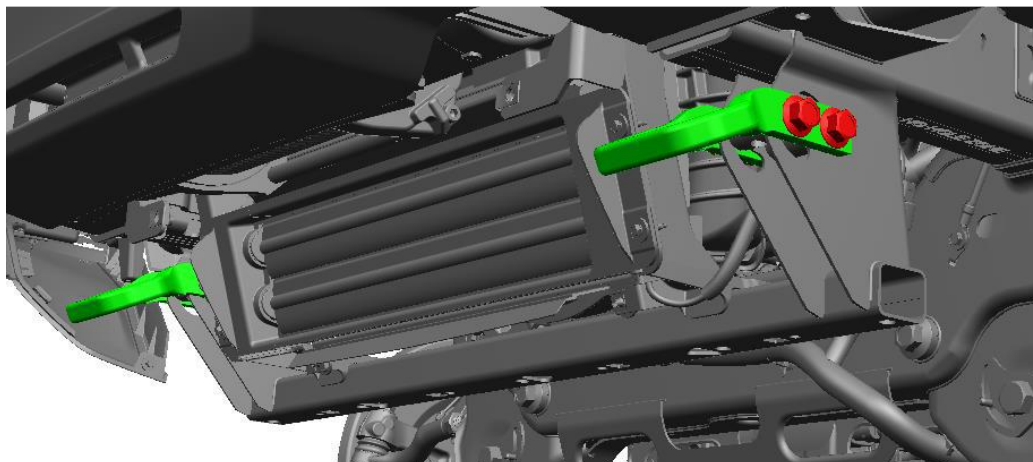

16. Reinstall the Underbody Skid Shield. To avoid washer contact to the winch housing replace the top two captured washer bolts (31.7mm washer OD) with two M8 x 25L hex flange bolts from the winch kit. The M8 x 25L bolts are in the bag with the 4 square

nuts. For bolt access it may be necessary to install the top two bolts and manipulate the H-brace before installing the bottom two bolts. **Torque to 22Nm.**

- a. Underbody Splash Shield (3) » Install
- b. Underbody Splash Shield Bolt (2) » Tighten [2x]
- c. Underbody Splash Shield Bolt (1) » Install and tighten [2x]

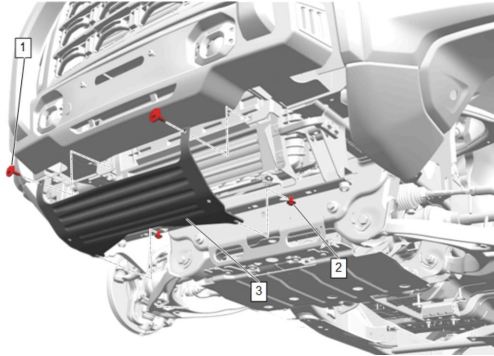

17. Zip tie both the winch harness bundle and the chassis ground to winch cable to the steering bracket (see pictures below in this step). Secure a 4.8 x 280 mm zip tie (item 11 in the controller fastener list) about every 6 inches on the steering bracket.

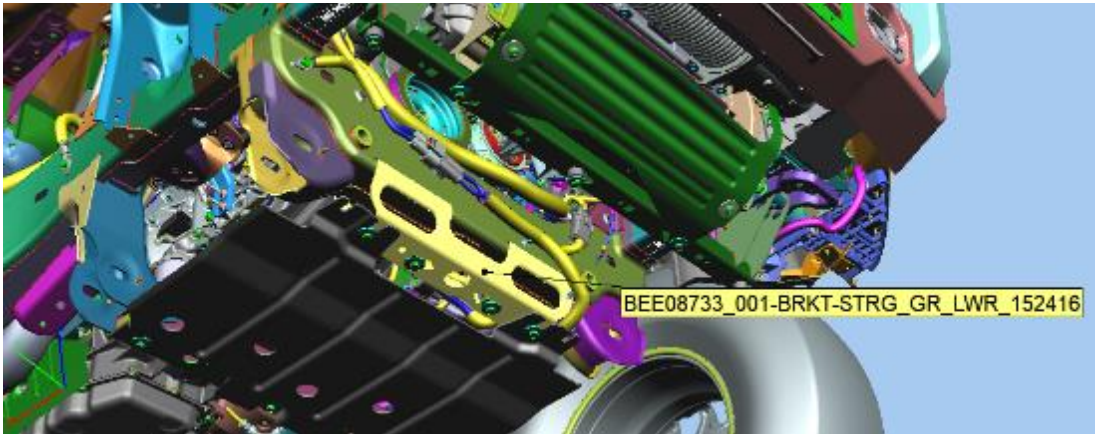

18. Install the skid plate retention screws and skid plate. ALL GMC MODELS GET ZR2 SKID PLATE.

- a. Underbody Skid Shield (1) » Install

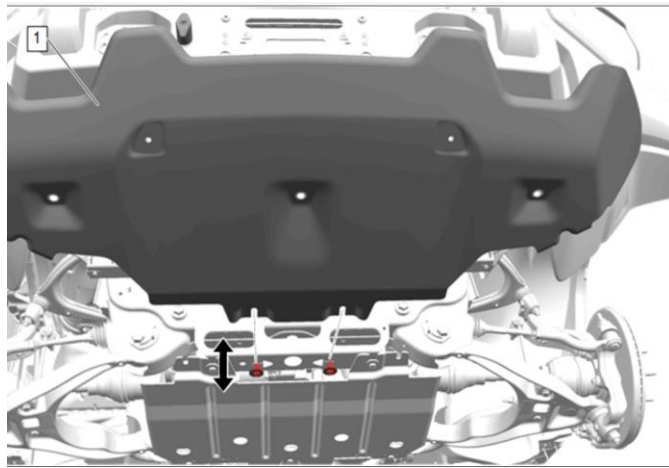

- b. Install the skid plate retention bolts. Torque the M8 bolts to 22 Nm.
 - i. Underbody Skid Shield Bolt (1) » Install and tighten [5x]
 - ii. Underbody Skid Shield Bolt (2) » Tighten [2x]

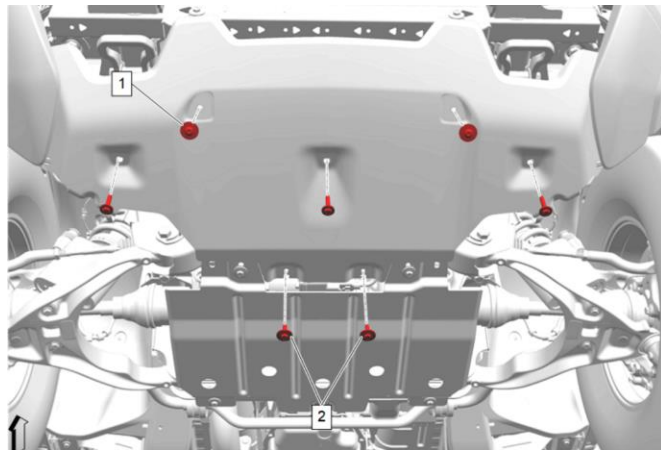

- 19. Install the front bumper fascia skid plate. Route the winch rope through the bumper fairlead opening. Front Bumper Fascia Skid Plate (1) » Install.

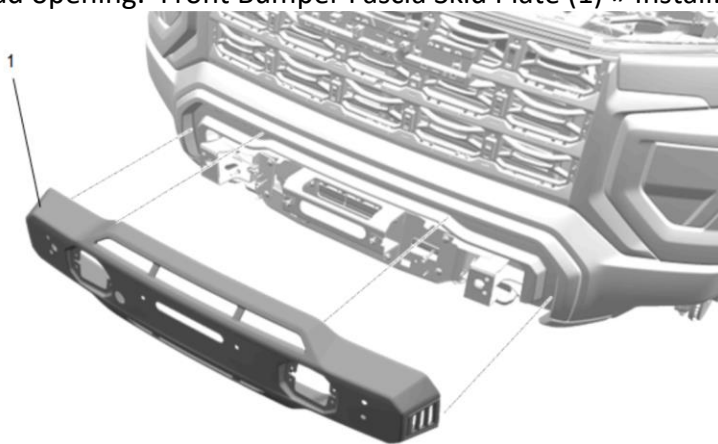

- 20. Install “COMEUP” fairlead on front bumper face using center screws and Adhesive Threadlocker Medium Strength Blue (GM PN 19333511). Route the winch rope through the fairlead. If installing the license plate, use the center bolts to attach the license plate assembly behind the fairlead at the same time. **Torque to 58Nm.**
 - a. Add GM Adhesive Threadlocker Medium Strength Blue (PN 19333511) available at GM Dealers to the threads of both Front License Plate Bracket Bolts (1). **Do not** install the flat washer or lock washer on the bolts that are included with

the winch fairlead, as they will potentially limit thread engagement especially when installing the front license plate bracket.

- b. (In states where required) Front License Plate Bracket (2) » Install
- c. Route the winch rope through the bumper fairlead opening. Fairlead » Install on top of the License Plate Bracket (in states where required) (2)
- d. Push the bolts with Adhesive Threadlocker through the fairlead and license plate (in states where required) holes.
- e. Front License Plate Bracket Bolt (1) » Install and tighten [2x]

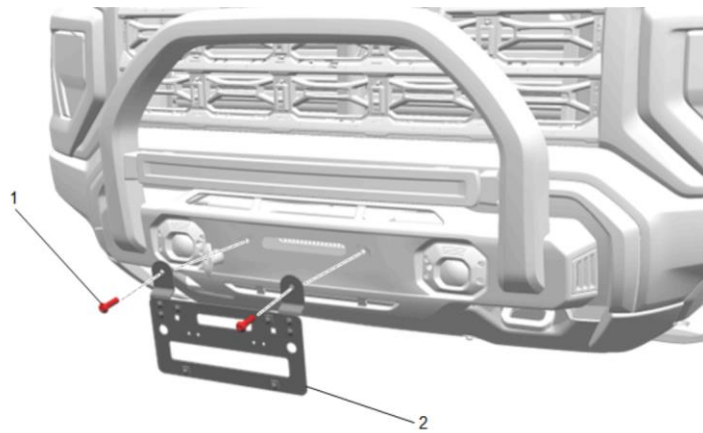
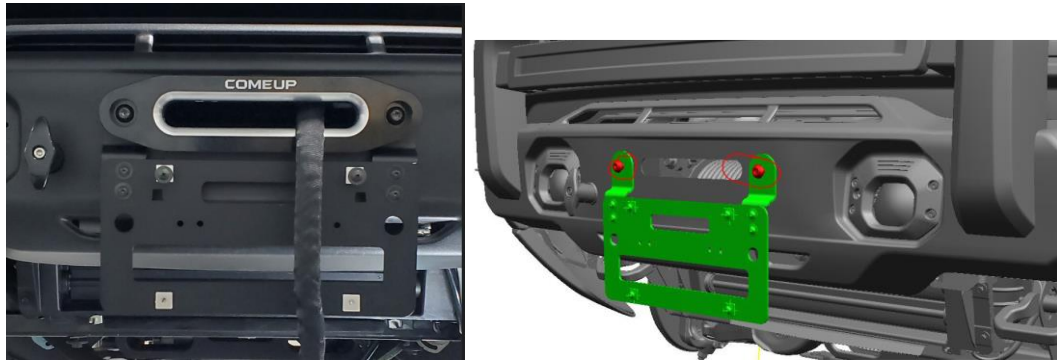

21. Install the front bumper impact bar. **Torque the nuts to 22Nm.**

- a. Front Bumper Impact Bar (1) » Install
- b. Front Bumper Impact Bar Nut - Left Side and Right Side (1) » Install and tighten [4x]

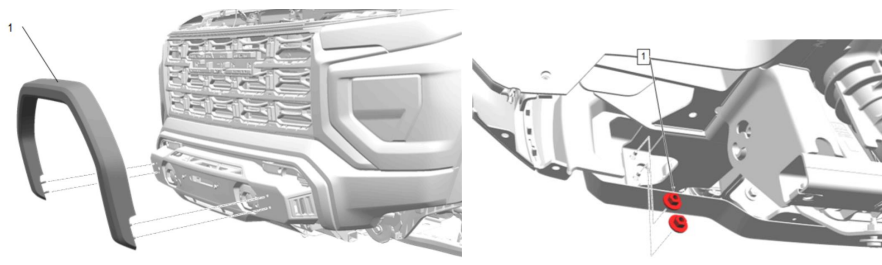

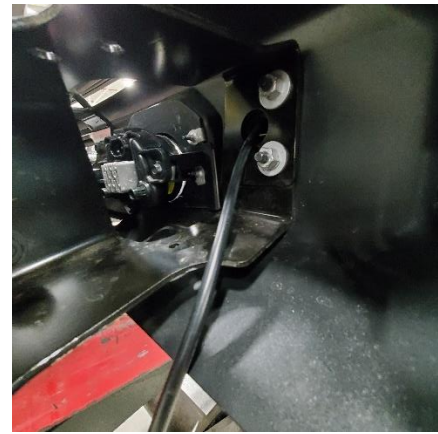
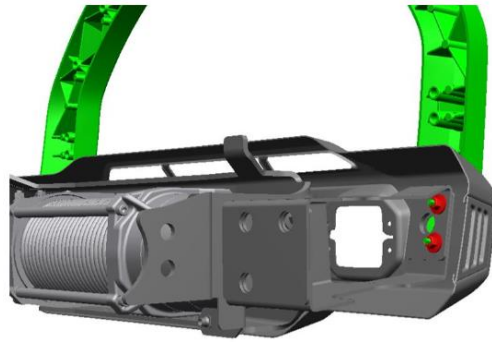

22. Reinstall the Winch Release T-handle.
 - a. Winch Release Handle (2) » Install
 - b. Winch Handle Bolt (1) » Install and tighten

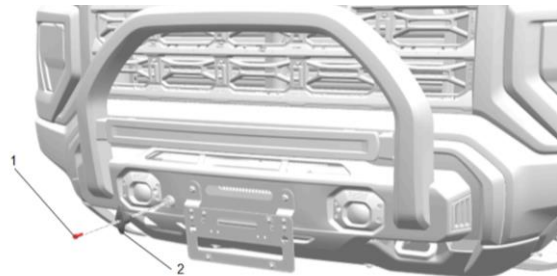

23. Winch install into the off-road bumper kit should now be complete. Electrical connections must still be reconnected (light bar connector and/or flush mount pod lamps).
24. Connect the fog lamps to the hanging wire harness



25. Slide the fog lamps through the off-road bumper into place. Use caution to not scratch the lens.
 - a. Connect the electrical connector.
 - b. Front Fog Lamp - Left Side and Right Side (1) » Install [2x]
 - c. Install all wire retainers.

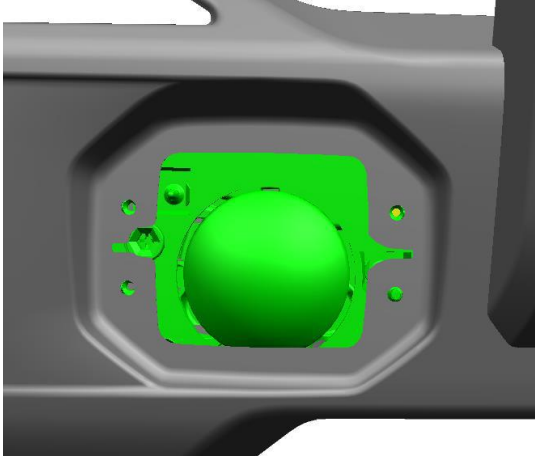
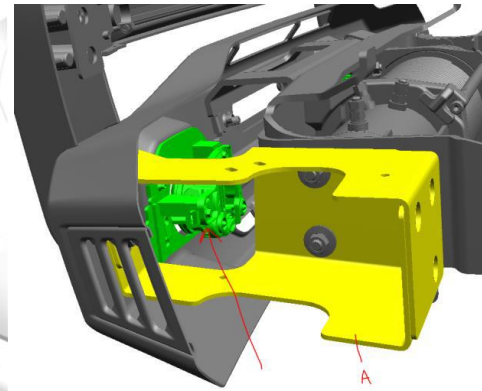
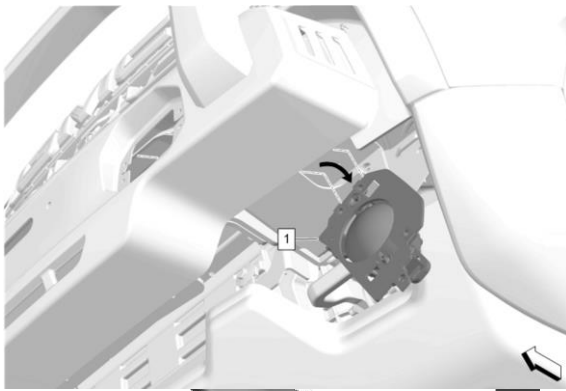

26. Install plastic fog lamp bezel and drive down 4/side screws being careful not to over torque and damage the plastic housing.

- a. Front Fog Lamp Opening Cover - Left Side and Right Side (2) » Install [2x]
- b. Front Bumper Fascia Bolt - Left Side and Right Side (1) » Install and tighten [8x]

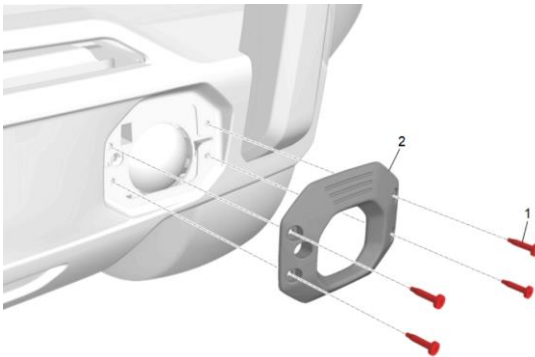

27. Snap the retainers into the off-road bumper (passenger side picture on the left, driver side on the right)



28. Reconnect the light bar harness (if present) after the fog lamps are reinstalled.
- a. {If equipped } It may be necessary to re-pin the off road lamp connector.
 - b. {If equipped } On the right side connect the off road lamp connector and retainers.

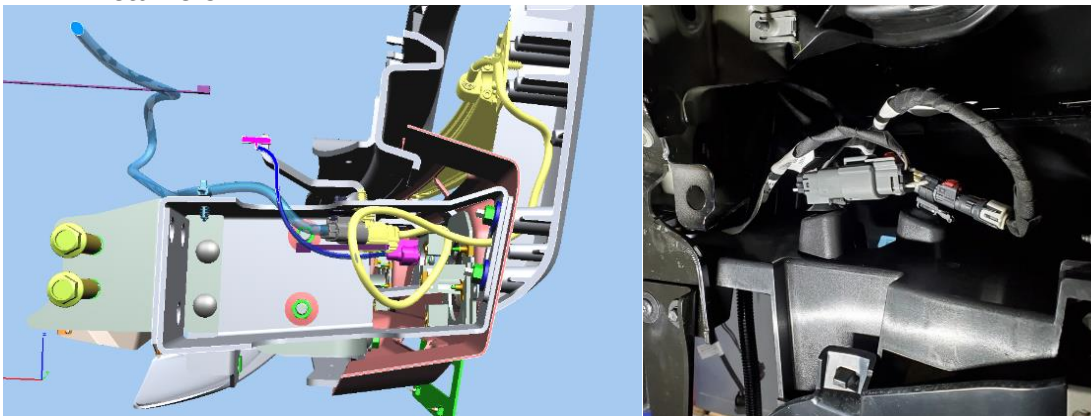

29. Reinstall the passenger and driver side front bumper fascia molding

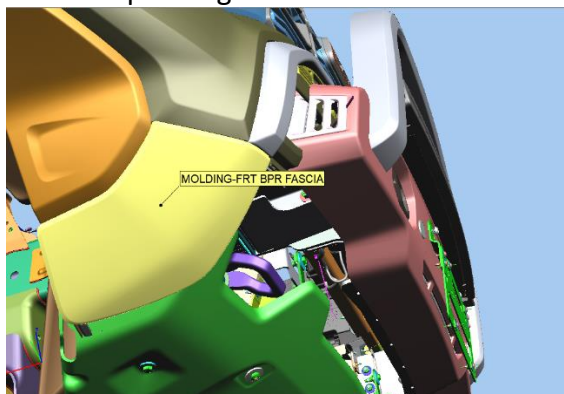

30. Zip tie both the winch harness bundle and the chassis ground to winch cable above the passenger side frame through the available hole by the front wheel speed sensor. Use a 4.8 x 280 mm zip tie (item 11 in the controller fastener list).

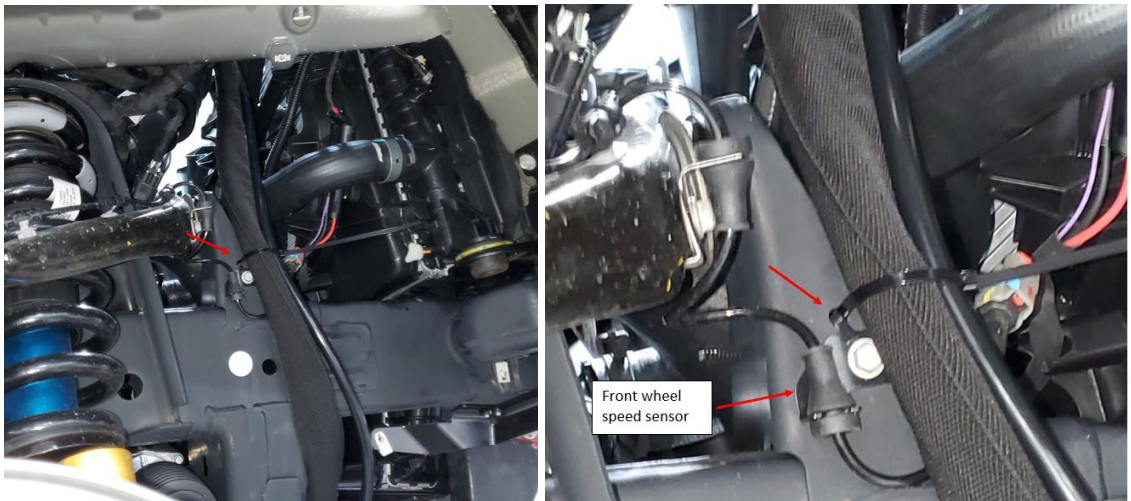

31. Reinstall the passenger side front wheel liner (See Service Information - Document ID: 6276716 [Document ID: 6276716 \(gm.com\)](https://gm.com)).

- a. For the rear half of the wheel house liner, reinstall the Front Wheelhouse Liner Retainer (1) and the single forward most Front Wheelhouse Liner Bolt (2).

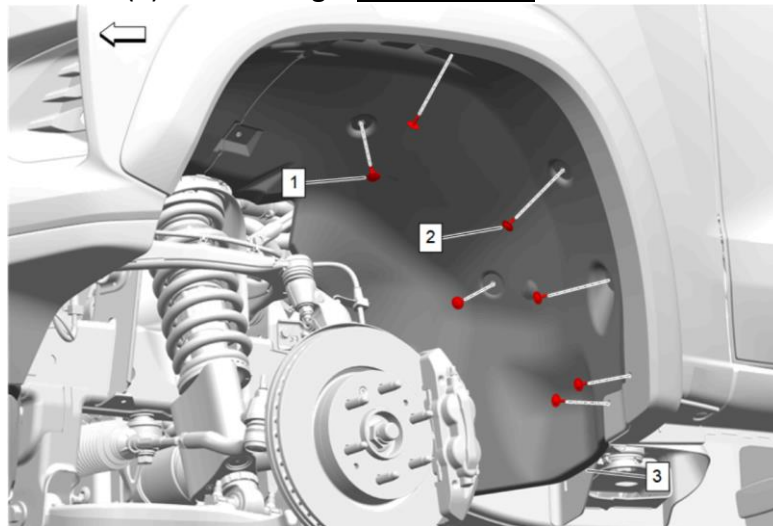

- b. Reinstall the front half of the wheelhouse liner. Front Wheelhouse Liner Bolt (1) » Install and Tighten [9x].

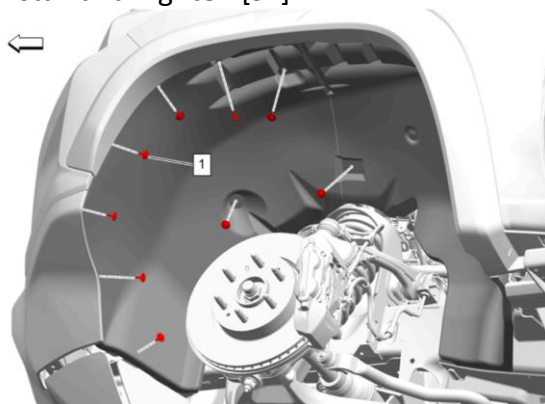

32. Connect the front side marker lamp connectors if needed.

33. Reinstall the front wheel and tire assemblies (off-road bumper not shown)

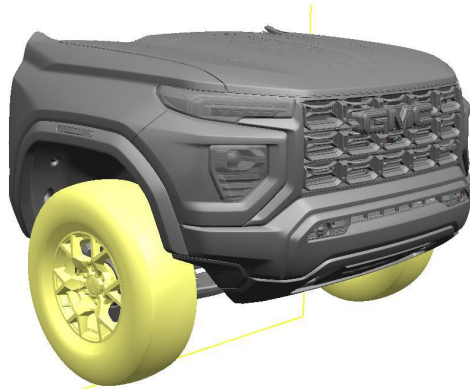

34. Lower the vehicle.

- I. **3-gang switch installation** - GM PN 84938259 (**ONLY IF REQUIRED IN STEP A – CENTER CONSOLE AUXILIARY SWITCH IS NOT AVAILABLE FOR WINCH USE**) (See Auxiliary Multifunction Switch Package Installation Service Information - Document ID: 6082772 [Document ID: 6082772 \(gm.com\)](https://gm.com))

Kit Components

84938259 Switch Pkg-Aux M/Func

84900983

85136353

84938261

84938260

1	12L/0401A	SWITCH PKG-AUX M/FUNC	Switch Kit	0	84938259
1	12L/0401A	SWITCH PKG-AUX M/FUNC	Switches - 3 gang	1	84900983
1	14F/0545B	INSTRUCTION - DEALER ACSRY	Instruction Sheet	1	84938261
1	1A2B/0140B	GUIDE-UP LOC	Switch template	1	85136353
1	12H/04025	HARNSS PKG-AUXRY W/G	Harness Kit	1	85136355
1	12H/0405A	HARNSS ASM-AUX M/FUNC SW W/G	Wiring Harness	1	84938260
6	12H/01545	STRAP ASM-WRG HARN	Tie straps	2	11500086
5	12H/00945	SPLICE-WIRE	splice	2	19300089

11509086

19300089

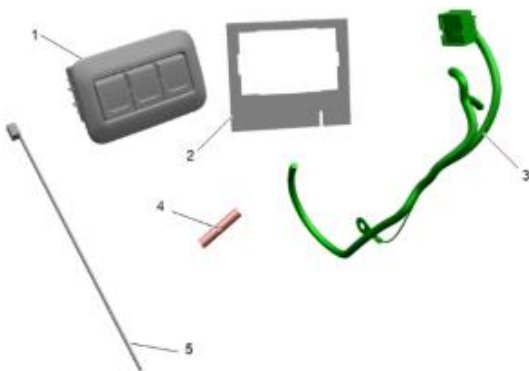

1. Remove the instrument panel knee bolster. Refer to [Instrument Panel Knee Bolster Replacement](#) in Vehicle Service Manual.

Note: There are two versions of the instrument panel knee bolster. One that may have a trailer brake switch (1) and one without trailer brake switch (2). Each show where the switch (3) will be located.

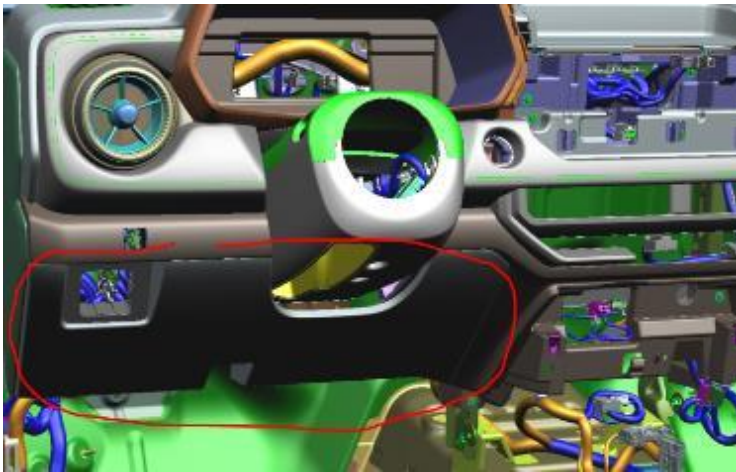
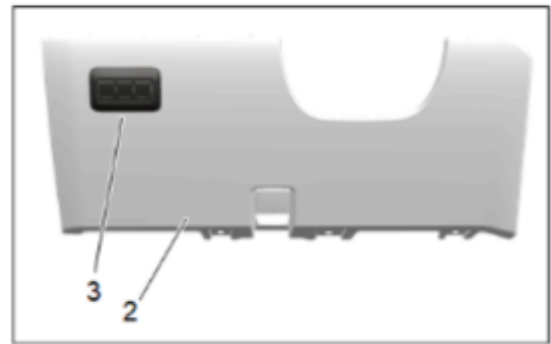
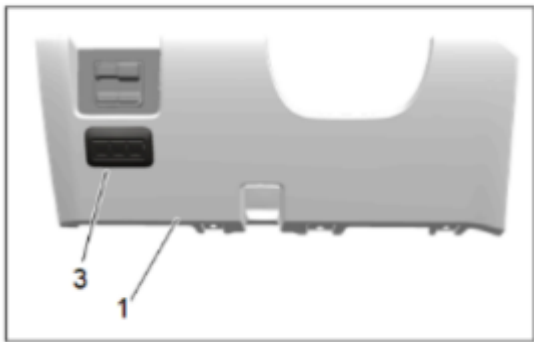

2. Locate the template (1) within the kit and position it into the ribs on the back (B-surface) of the panel (2) matching up the locator slot (3) as shown.

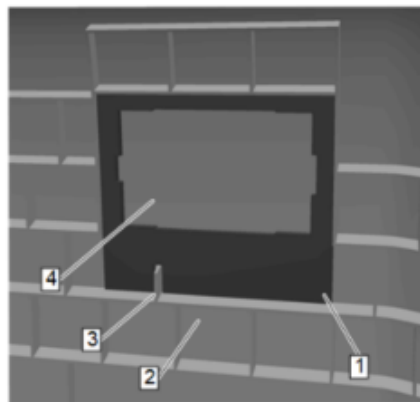

3. Using a suitable cutting tool, cut out a clean opening (4) inside the trim template of the knee bolster trim for the switch to fit in and make sure the edges are free from any burrs (clean up, if necessary).
4. Locate the switch (1) within the kit and snap it into position from the front side (A-surface) of the knee bolster into the newly cut hole (2). Make sure the cut-out opening allows switch to sit flat on panel with no visible openings in the trim.

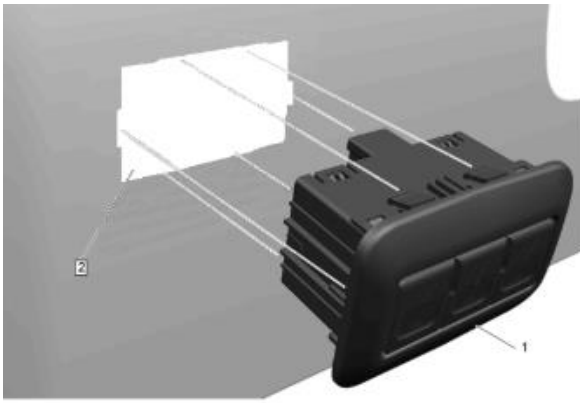

5. Open the hood and locate the winch control module. Find the long (2040 mm) black 18 AWG wire originating from the control module. Route the wire to the driver side under the hood cowling at the push pins. Run 4.8 x 190 mm zip ties (item 10 in the controller fastener list) through each push pin on the underside of the cowling. Secure the wire to each push pin with the zip ties.

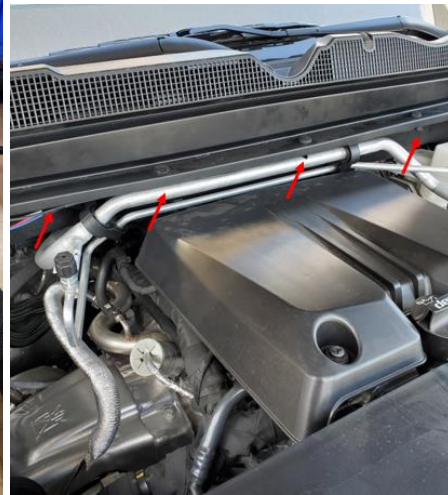
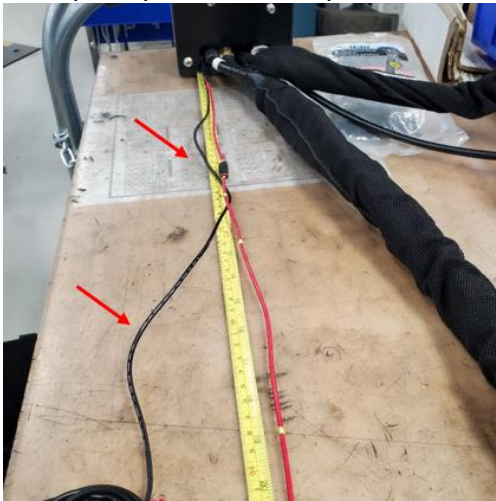

6. From inside the vehicle on the driver's side below the instrument panel, locate the wire harness grommet (1).
Caution: Always check position of hole before cutting/drilling. Failing to do so may cause damage to the vehicle, misalignment of components or the inability to install the accessory.

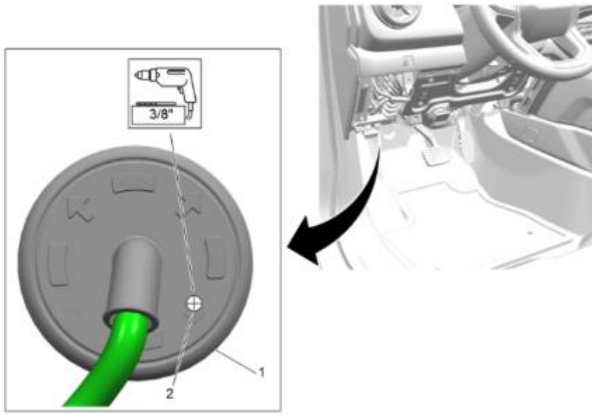

7. Poke a hole (2) near the 4 o'clock position using a straight pick through the inside and outside grommet (1) making sure to keep it centered between the grommet's outer edge and the wire bundle to avoid damage to the grommet. (A drill with 3/8" bit can be used as an alternative method).
8. Using the pick as a fish tool (or replace with a longer fish tool if preferred), leave it in the grommet hole (2) and locate it underhood.
9. Remove the single bolt (1) of the reservoir (2) and pull the reservoir (3) off the mount (4) and reposition to gain access to fish line more easily.

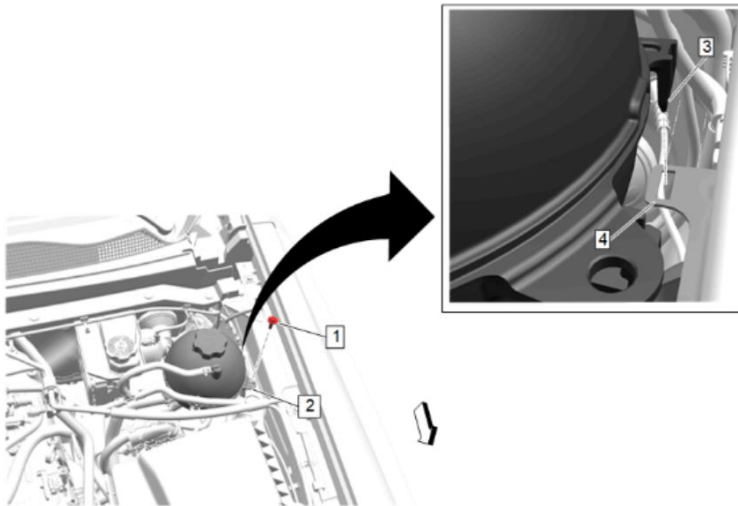

10. Route the long (2040 mm) black 18 AWG wire originating from the control module (1) rearward and under the brake reservoir connector/line making sure it's not tangled. Tape the wire (1) to the fish tool and pull or push through grommet (2) into the interior compartment. Un-tape from the fish tool and set aside.

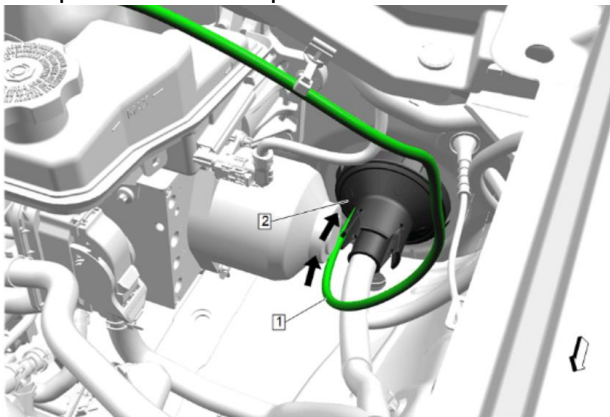

11. Locate the switch wire harness (1) from the bag within the kit. **Locate the White and Yellow wire bundle on the switch harness. Remove enough tape to expose 3 ½ inches of both wires.**

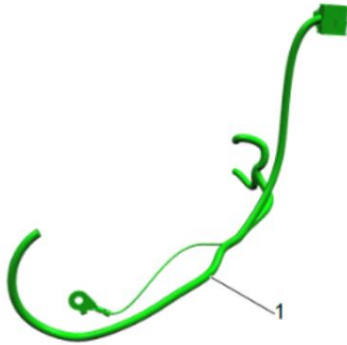

12. From the interior driver foot area butt splice the black wire originating from the winch control module to one of the available AUX switches. There are 3 colored wires (Green = AUX 1, Brown = AUX 2, Blue = AUX 3) in the bundle, one associated with each AUX switch. First, check if the Green wire on the switch wire harness is available for the AUX 1 switch. If it is already allocated to another system, use one of the other wires for the other AUX switches. Refer to [Wire to Wire Repair](#) in Vehicle Service Manual.



a. Switch Wiring

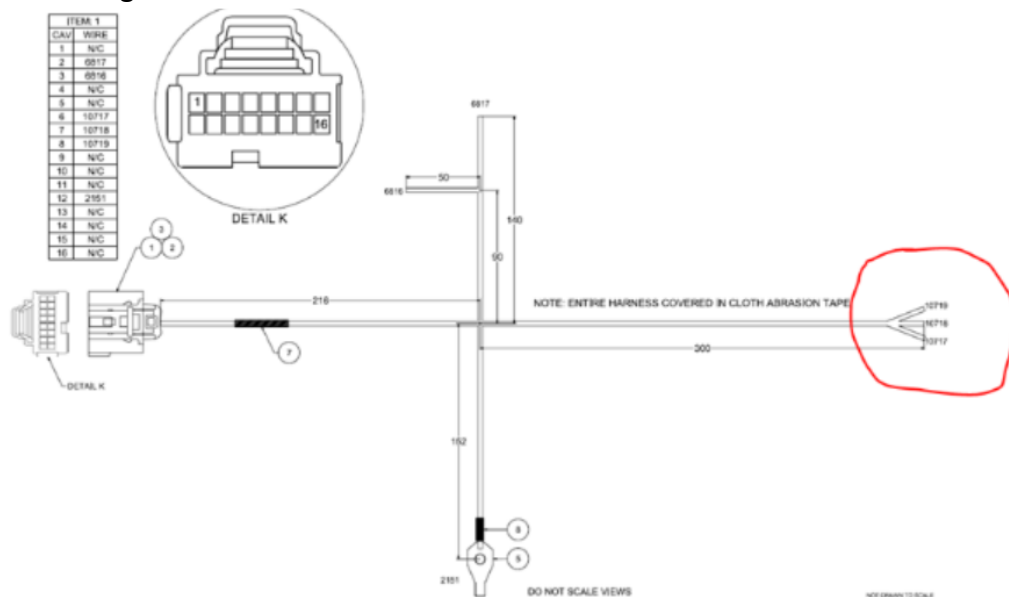

13. Install the switch harness ground wire metal eyelet under the ALDL connector. Remove the two ALDL fasteners. Place the harness metal eyelet on the surface of the metal

beam under the inboard bolt. Reinstall the ALDL connector on top. Torque the two bolts to 22 Nm.

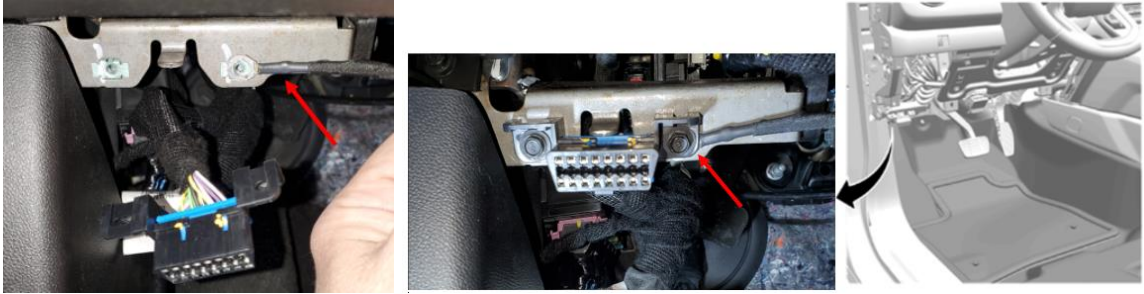

14. Locate the body control module (1) on the driver side footwell area and remove the connector covers (2) from connectors X4 (light grey color) and X5 (aqua color).

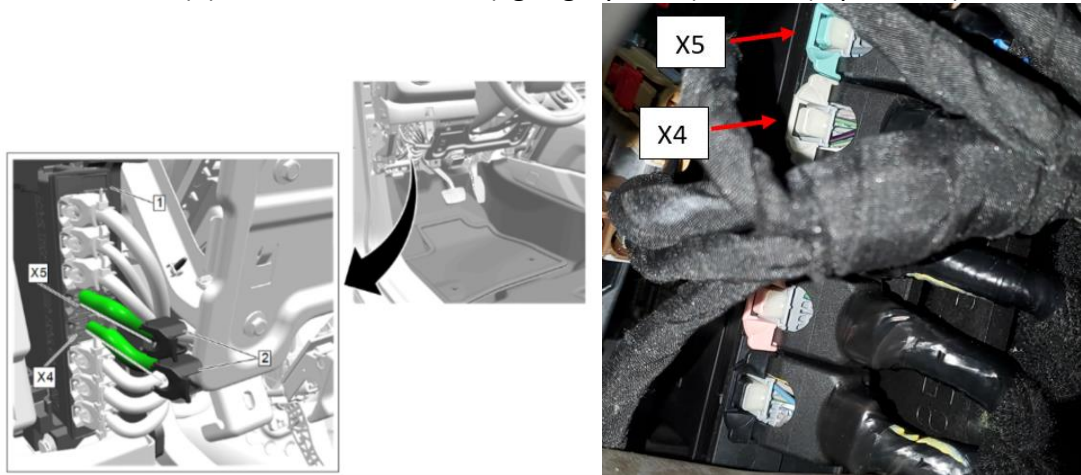

15. Remove connectors X4 (light grey color) and X5 (aqua color) from the body control module (1).

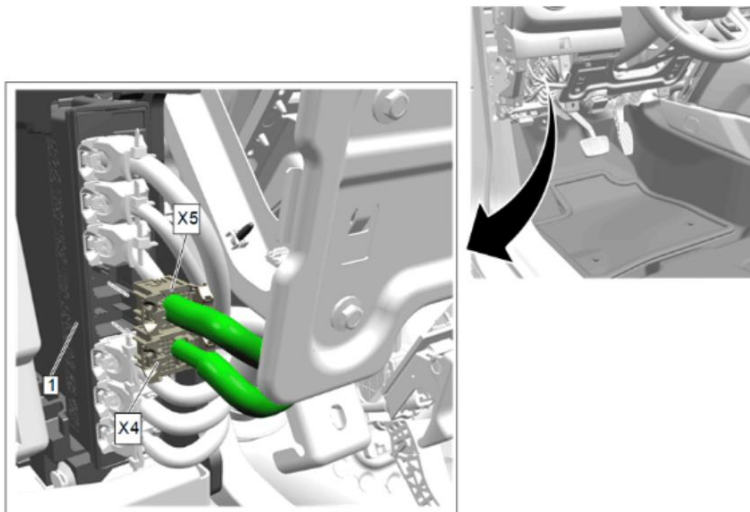

16. Locate the White wire coming from cavity #21 of the BCM connector X4 removing any tape necessary. Locate the White wire on the switch harness and confirm there is 3 ½ inches of exposed White wire. Splice it to the BCM wire so there is enough wire length on both sides of the splice. Refer to [Wire to Wire Repair](#) in Vehicle Service Manual.

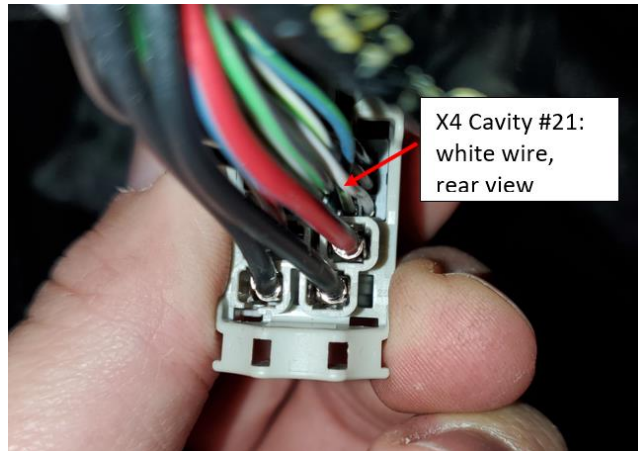
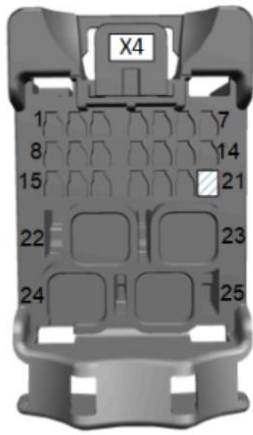

17. Locate the Yellow wire coming from cavity #6 of the BCM connector X5 by removing any tape necessary. Locate the Yellow wire on the switch harness and confirm there is 3 ½ inches of exposed Yellow wire. Splice it to the BCM wire so there is enough wire length on both sides of the splice. Refer to [Wire to Wire Repair](#) in Vehicle Service Manual.

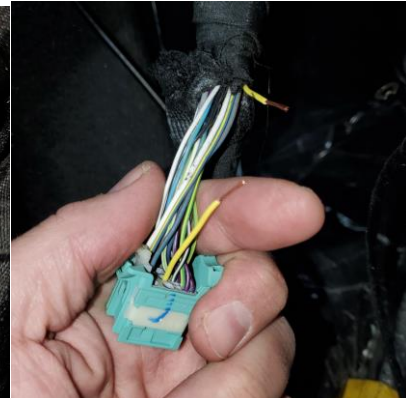
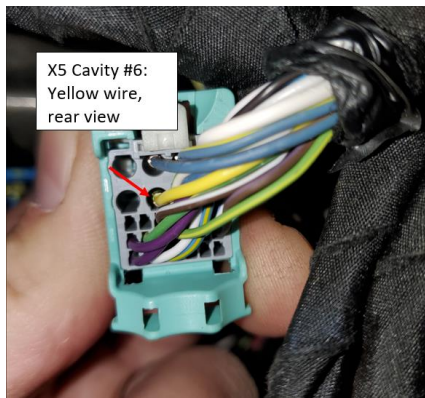

18. Tape the splices neatly to the main harness wiring so they won't be damaged and re-connect connectors X4 and X5 to the body control module (1).

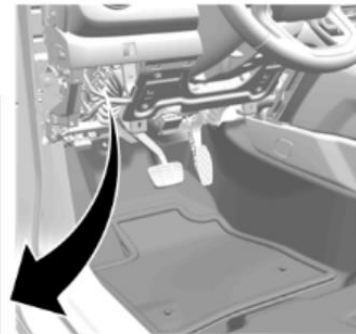
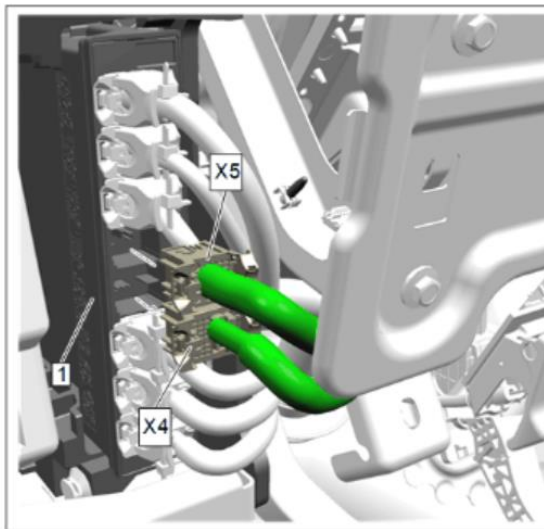

19. Re-install the connector covers (2) to connectors X4 and X5 on the body control module (1).

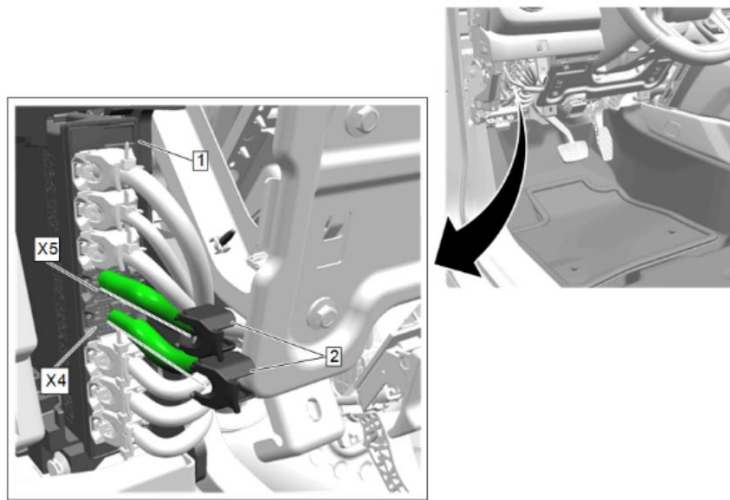

20. Untangle the remaining wiring so that the 16-way connector (1) will be near the position of the switch and route the wire as shown using a service loop (2). Secure the wire in the locations shown with three of the provided tie straps (cut excess tie strap material after securing).

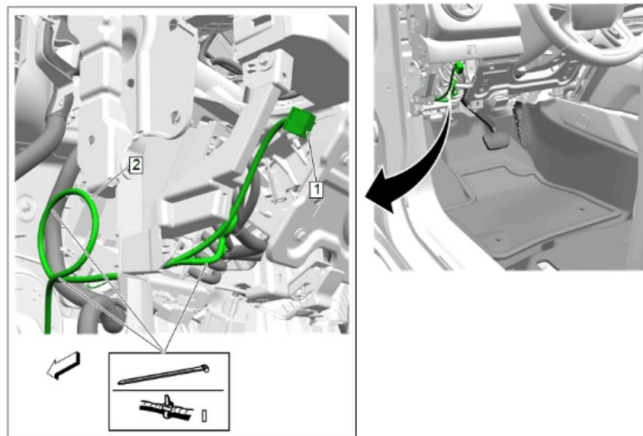

21. Re-install the instrument panel knee bolster. Refer to [Instrument Panel Knee Bolster Replacement](#) in Vehicle Service Manual.

22. Connect the trailer brake switch making sure the CPA is locked, (if equipped). Connect the 16-way connector (2) of the new switch wiring to the back of the switch (1) holding the front securely so the switch doesn't pop out. Engage the red CPA (3) to lock connector.

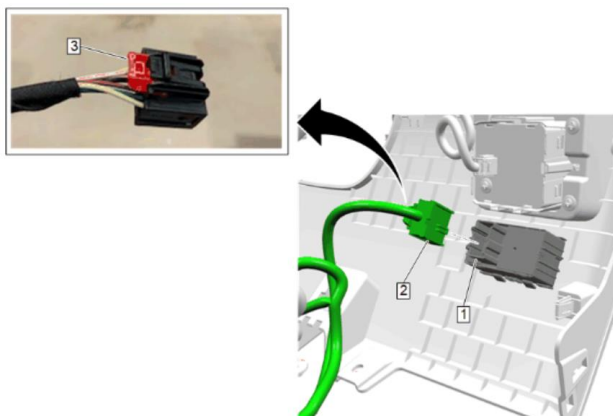

23. Use tape (not provided) to make sure there is no wire that is in danger of being pulled or accidentally stepped on. It's very important to make sure nothing dangles or impedes into the driver's foot zone.
24. Seal both sides of the grommet where the wires passed through with a water proof sealant (not provided).
25. Reposition the reservoir (3) to the mount (4) and re-install the bolt (1) to reservoir (2) and tighten bolt to 9 N.m (80 lb in).

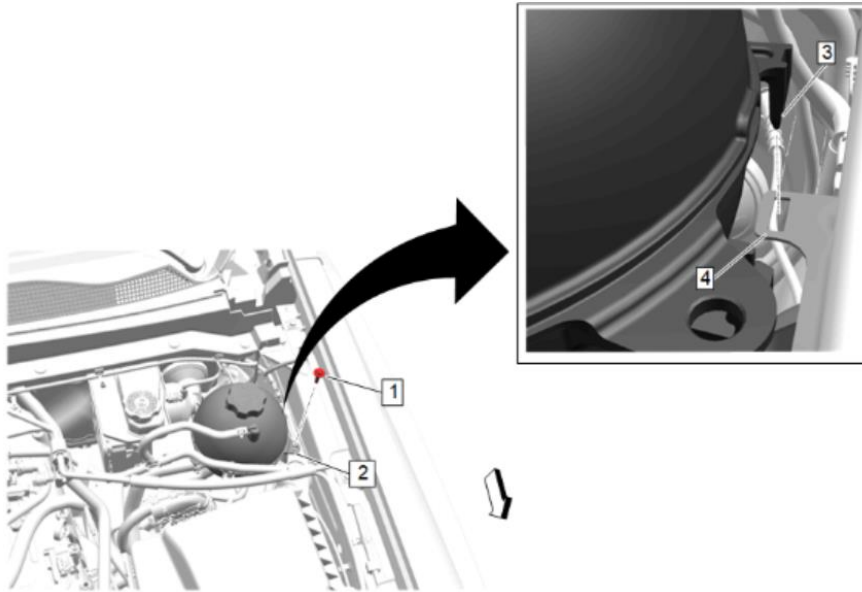

26. After all vehicle battery connections are made (see Section I. Final harness and battery connections & winch operation check) place the vehicle ignition in run or accessory position and try the AUX1 switch. The backlighting at the word "AUX1" should light whenever the vehicle is on. Check the AUX1 switch to make sure the amber indicators is working. The switch will light when pressed in and should go off when in the out position.

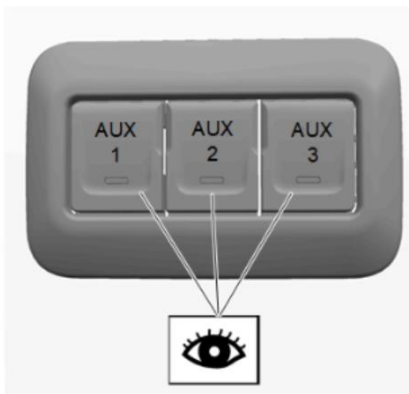

Note: You may need to cover the switch area to make dark enough to see

J. Final harness to battery connections & Winch operation check

1. If an Accessory Power Box (see picture below) is installed in the vehicle confirm the 60A fuse/bracket assembly (2) is attached to the battery post (1) with 8mm nut (3) or use one supplied in the winch kit. Make sure bracket sits flat and remove any excess cable glue with knife if necessary.

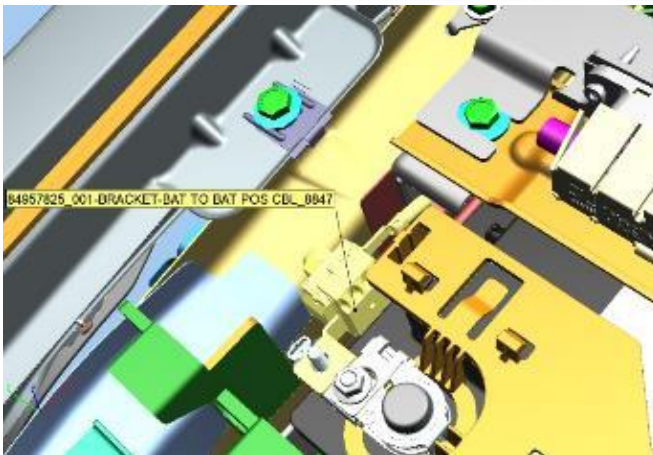
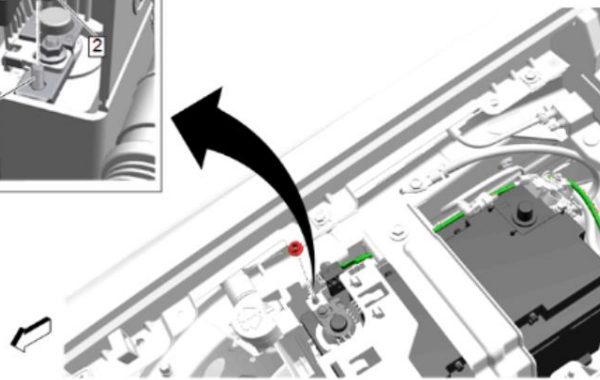
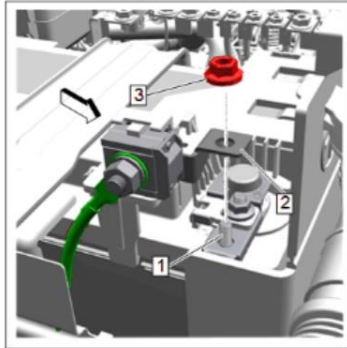
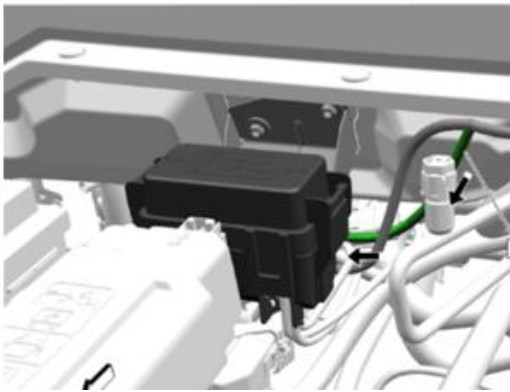

2. Overlay winch power cable on same battery post (1) and secure with M8 nut. If Accessory Power Box is not installed, then use the M8 x 1.5P flange nut supplied in the winch kit (item 12 in controller fastener list). Tighten nut to 13 N.m (115 lb in).

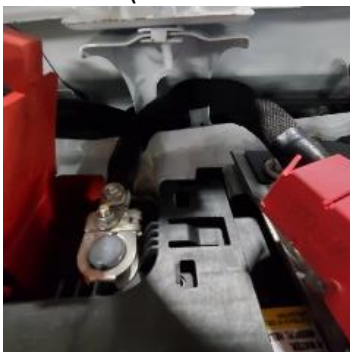

3. Connect the loose black 2AWG cable attached to the chassis ground stud to the battery negative terminal.

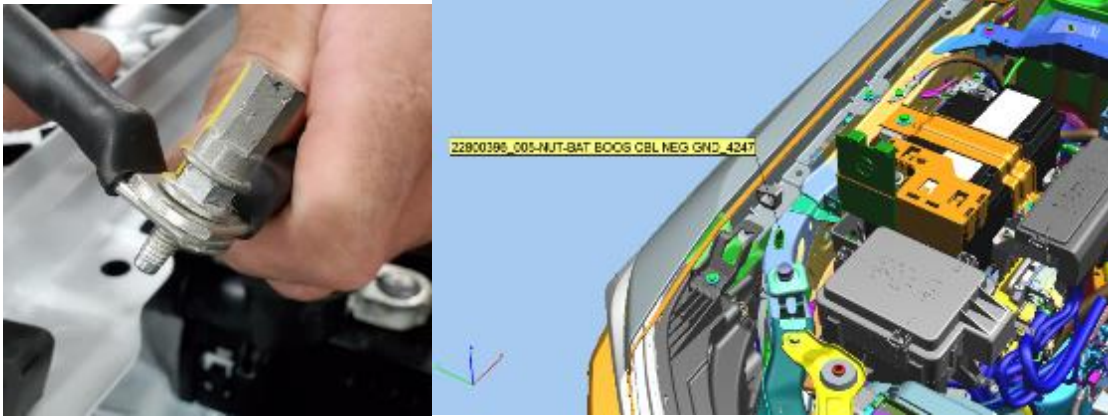

4. As the battery was disconnected and the 3-gang switch was installed **follow the procedure to clear all faults** (See Diagnostic Repair Verification Service Information - Document ID: 1556771). Refer to [Diagnostic Repair Verification](#) in Vehicle Service Manual.
5. Turn on winch module with 3-gang switch. The winch control module will beep, as it is not paired with the wireless blue tooth transmitter. Attach the wired remote cable to the wired remote plug on the cross-battery bracket. While lightly pulling outward on the winch rope check that the winch operates both outward and inward.



Note: a wireless remote control is also included and can be paired following the instructions provided here:

[Pairing the wireless transmitter with COMEUP Seal Slim winch - YouTube](#)

6. Turn off the winch by pressing the 3-gang switch button in the driver compartment. When off the winch controller will no longer beep.
7. Install hook on winch rope. The shaft is press fit into the aluminum coupling. Attach the hook to one of the tow hooks. Reoperate the winch (as needed) to take in any loose winch rope slack. Turn off the winch power upon completion.



- Place the wired remote control (item 21 in parts list), handsaver strap (item 22), wireless transmitter (item 23-7), bumper fascia plug, and winch documentation in the vehicle for the customer's future use and reference.

Warning

- The winch is not intended to be used in any manner for the movement or lifting of personnel.
- The rated line pull shown is based on the first layer of rope on the drum.
- The rope winding on the drum shall remain 10 wraps from the drum to support the rated load.
- Manufacturer is not responsible for the results of misuse, misapplication, faulty installation or abuse of synthetic rope in any way.

Parts List

Item No.	Description	Part No.	Qty
1	Waterproof motor w/housing 12V	883601	1
2	Tie bar kit	883132	1
3	Motor coupling	880005	1
4	Drum bushing	880006	2
5	Drum kit	881521	1
6	Gearbox support rack	883578	1
7	Synthetic rope	883248	1
8	1 st shaft	880011	1
9	3 rd ring gear kit	880114	1
10	3 rd stage carrier	880115	1
11	2 nd stage carrier	880116	1
12	1 st stage carrier	880117	1
13	1 st & 2 nd ring gear	880118	1
14	1 st pinion	880119	1
15	Clutch kit	884114	1
16	Gear box kit	882524	1
17	Cone brake disc kit	880122	1
18	Brake clutch base	881100	1
19	Brake cover kit	882525	1
20	Mounting hardware	883605	1
21	Remote control	880126	1
22	Handsaver strap	880026	1
23	Control box 12V	884112	1
23-1	Wireless receiver	884110	1
23-2	Detachable control pack 12V	884111	1
23-3	Battery ground cable	884110	1
23-4	Winch ground cable	884115	1
23-5	Relay module	884249	1
23-6	Splice wire	884260	1
23-7	Wireless transmitter	883622	2
23-8	Mounting rack kit	884257	1
24	Sling hook	882477	1
25	Hawse fairlead	881061	1

Winch Assembly

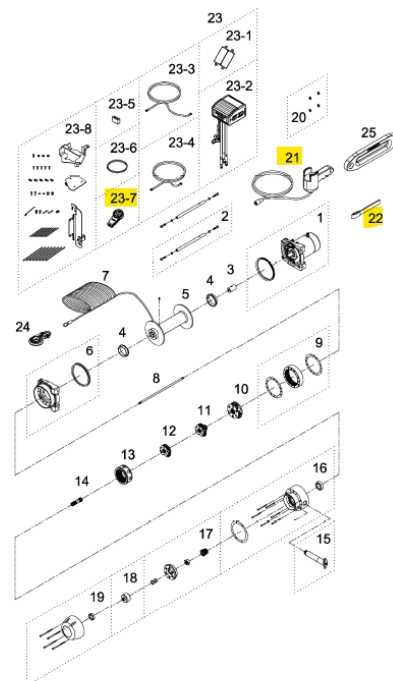

2023/01/06 Ver.03

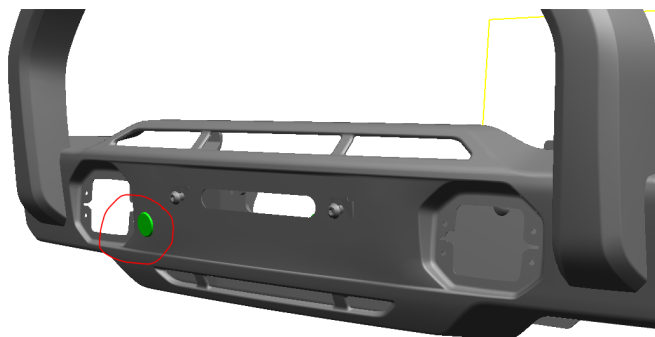

- Installation is complete.