

Assist Step Kit Installation

Table 1: [Kit Contents – Front Step](#)

Table 2: [Kit Contents – Rear Step](#)

Installation Instructions Part Number

84808893

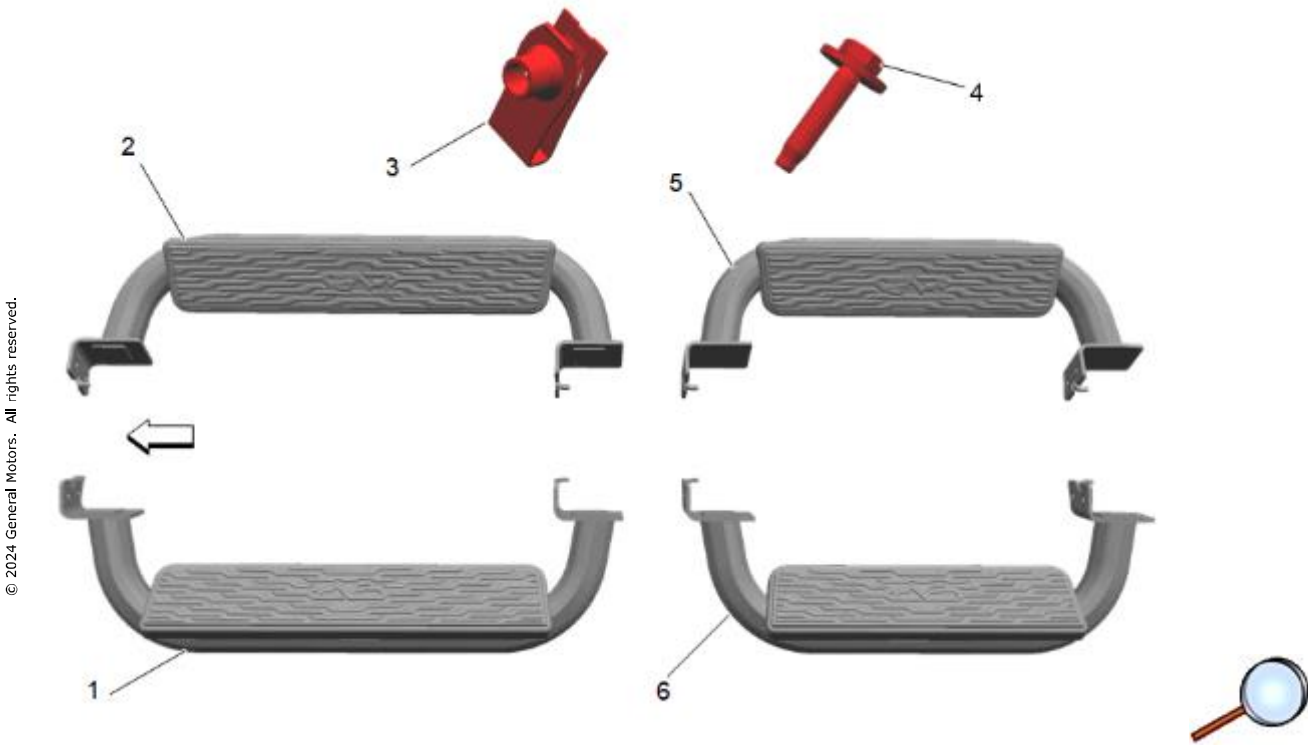

© 2024 General Motors. All rights reserved.

Kit Contents – Front Step

Item	Description	Qty:
1	Assist Step Assembly Left Side Front	1
2	Assist Step Assembly Right Side Front	1
3	M8 U-Nut (Part of Attachment PKG)	8
4	M8 Bolt (Part of Attachment PKG)	8
—	Instruction Sheet	1

Kit Contents – Rear Step

Item	Description	Qty:
3	M8 U-Nut (Part of Attachment PKG)	8

Item	Description	Qty:
4	M8 Bolt (Part of Attachment PKG)	8
5	Assist Step Assembly Right Side Rear	1
6	Assist Step Assembly Left Side Rear	1
—	Instruction Sheet	1

Torque Table

8mm Hardware torque to 25N•m (18 lb ft)

Tools Required

- Torque Wrench
- 13mm Socket
- 3/8" drive Ratchet
- 3" 3/8" drive extension

Procedure

Note: Read entire instruction sheet thoroughly before starting.

Note: Determine LH assist step assembly and RH assist step assembly.

Caution: Use the correct fastener in the correct location. Replacement fasteners must be the correct part number for that application. Fasteners requiring replacement or fasteners requiring the use of thread locking compound or sealant are identified in the service procedure. Do not use paints, lubricants, or corrosion inhibitors on fasteners or fastener joint surfaces unless specified. These coatings affect fastener torque and joint clamping force and may damage the fastener. Use the correct tightening sequence and specifications when installing fasteners in order to avoid damage to parts and systems.

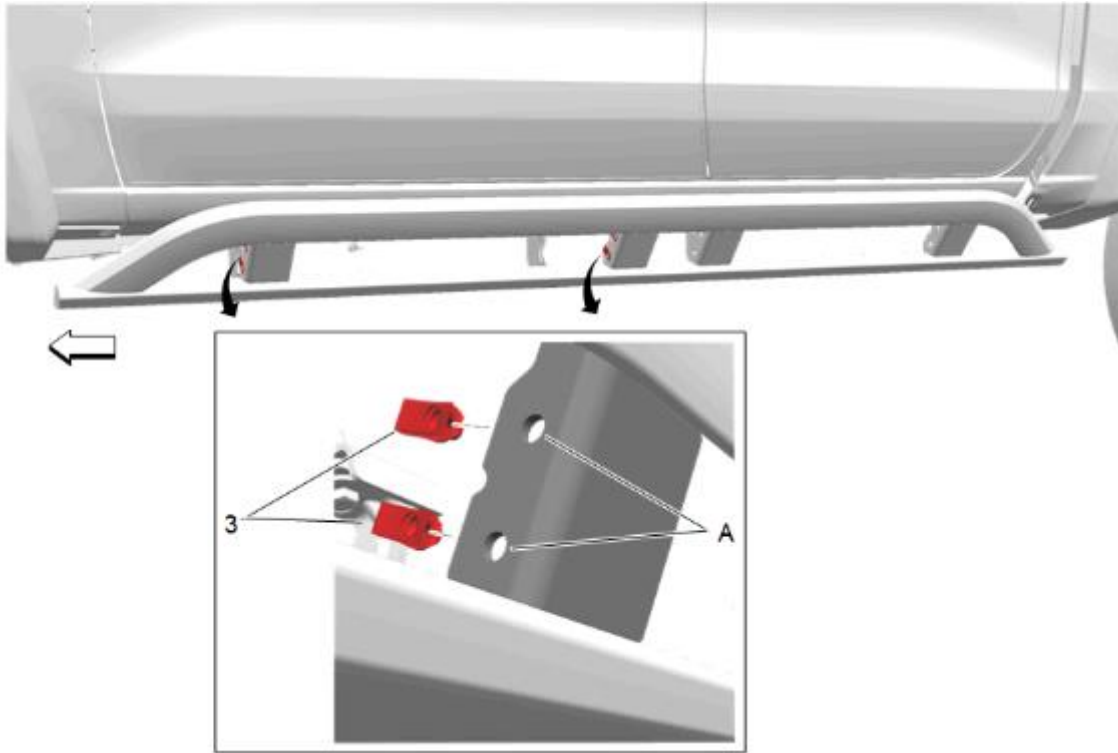

1. Install the four - U-nuts (3) into existing holes (A) on rocker protector stanchion. Refer to graphic for locations and orientation of U-nuts. Install the U-nuts with the threads facing rear of vehicle inside the rocker protector stanchion.

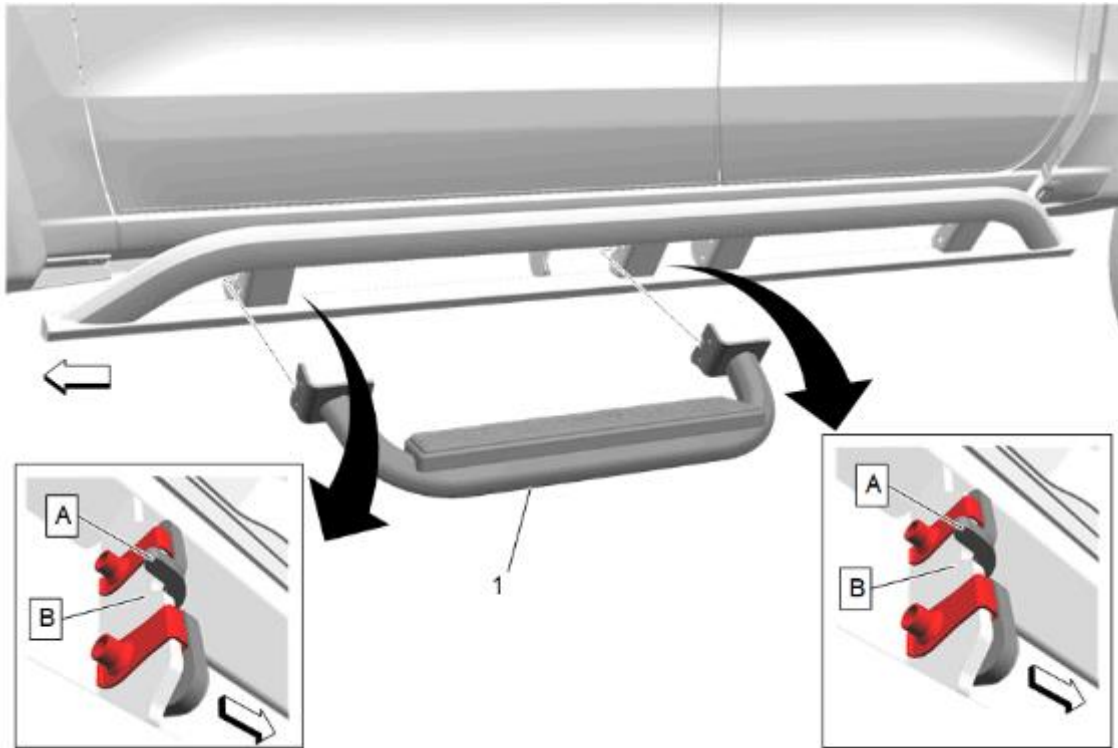

2. Position the Step Assembly LH side (1) to the rocker protector stanchion making sure the hook (A) is engaged to groove on back of stanchion (B).

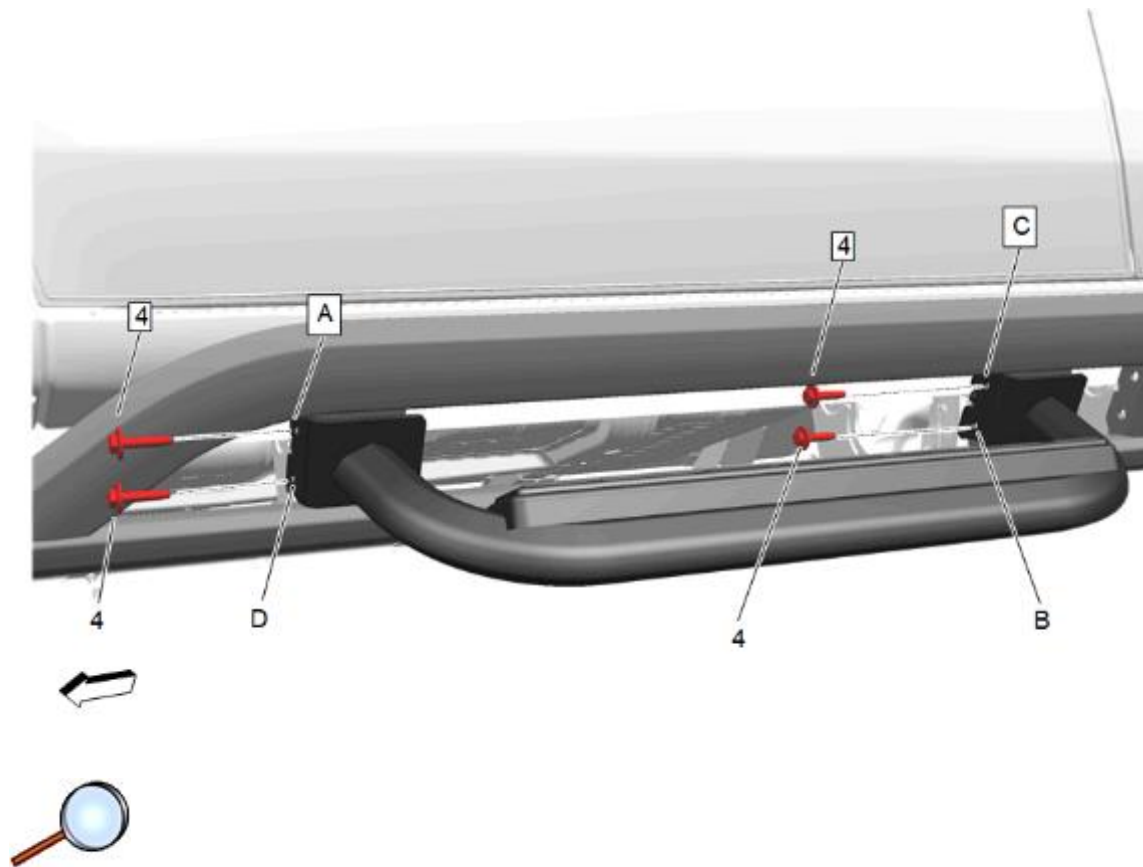

3. Loosely install the four M8 bolts (4) in the locations shown.
4. Tighten the M8 bolts (4) in order as follows: (A), (B), (C) and (D) to 25N•m (18 lb ft).
5. Repeat steps 1 through 4 for front step assembly RH (2) and for rear steps RH (5), LH (6).
6. Verify correct torque on all hardware.